

# PILOT'S OPERATING MANUAL

## BELLANCA



DECATHLON (Standard)  
DECATHLON CS  
SUPER DECATHLON

BELLANCA AIRCRAFT CORPORATION  
Alexandria, Minnesota 56308  
Osceola, Wisconsin 54020

\* Model year is indicated by serial number suffix.

Issued: September, 1979

## LOG OF REVISIONS

Revision	Pages Affected	Description Change	Date
A	ii,3-3,3-5,3-7, 3-8,3-9,3-14, 6-3,7-1, 7-6, checklist.	Clarification and minor changes, add Acro harness warning.	5/80

## FOREWORD

This manual has been prepared to inform the pilot of features and systems incorporated into the Bellanca Decathlon, Decathlon CS and Super Decathlon. All three Decathlons share the same 8KCAB model number and many of the systems and limitations are the same. However, they differ in certain important areas; be certain you know which model you wish to reference.

Decathlon	Lycoming AEIO-320-150 HP	Fixed Pitch Propeller
Decathlon CS	Lycoming AEIO-320-150 HP	Constant Speed Propeller
Super Decathlon	Lycoming AEIO-360-180 HP	Constant Speed Propeller

The Decathlon has been given the FAA Civil Aircraft Type Designator BL30.

Recommended operating procedures and performance data are provided so that maximum utilization can be obtained with the utmost of safety, economy and serviceability.

It is strongly recommended that the pilot be familiar with the aircraft and this manual prior to flight. It is considered mandatory that the pilot familiarize himself with the Emergency Procedures Section prior to flight.

This manual applies only to the aircraft as indicated on the cover page. Use of this manual with other aircraft is not recommended.

This manual does not replace the FAA Approved Airplane Flight Manual. If an inconsistency exists between the manuals, the FAA Approved Airplane Flight Manual is to be the authority.

The words "WARNING", "CAUTION", and "NOTE" are used throughout the manual with the following definitions:

### WARNING

An operating procedure, practice or condition, etc. which may result in injury or fatality, if not carefully observed or followed.

### CAUTION

An operating procedure, practice or condition, etc. which if not strictly observed, may damage the aircraft or equipment.

### NOTE

An operating procedure, practice or condition, etc. which is essential to emphasize.

**TABLE OF CONTENTS**

SECTION I	OPERATING LIMITATIONS.....	1-1
SECTION II	EMERGENCY PROCEDURES.....	2-1
SECTION III	NORMAL OPERATING PROCEDURES.....	3-1
SECTION IV	FLIGHT PERFORMANCE.....	4-1
SECTION V	WEIGHT AND BALANCE.....	5-1
SECTION VI	AIRCRAFT AND SYSTEMS DESCRIPTION...	6-1
SECTION VII	SERVICING REQUIREMENTS.....	7-1

This Manual is current as of its issue date and will be revised as necessary by Service Letters published by Bellanca Aircraft Corporation. Service Letters are distributed to Bellanca Dealers and to those who subscribe to the Service Publications Subscription Service. If you are not receiving this service, you must consult with your Bellanca Dealer for information concerning the revision status of this Manual. Changes to the Manual should be installed and the Log Of Revisions updated immediately after receipt of such revisions. The Manual should not be used for operational purposes unless it is maintained in a current status.

# SECTION I

## OPERATING LIMITATIONS

### INDEX

GENERAL.....	1-1
AIRSPPEED LIMITATIONS.....	1-2
POWERPLANT LIMITATIONS AND INSTRUMENT MARKINGS.....	1-3
WEIGHT AND BALANCE LIMITS.....	1-4
FLIGHT LOAD FACTORS.....	1-4
KINDS OF OPERATION.....	1-5
UNUSABLE FUEL .....	1-5
INVERTED FLIGHT.....	1-5
MANEUVERS.....	1-6
REQUIRED PLACARDS.....	1-7

### GENERAL

This section lists all powerplant and airframe operating limitations for each of the three models, Decathlon, Decathlon CS and Super Decathlon. These limitations are also indicated in the aircraft in the form of placards, instrument color markings and in the FAA Approved Airplane Flight Manual. Information or limitations which is not indicated for a particular model is common to all three models.

**AIRSPEED LIMITATIONS****NOTE**

Limitations are applicable to both Normal and Acrobatic Category except where designated as applying to only one category.

Airspeed Designation	Decathlon & Decathlon CS CAS MPH	Super Decathlon CAS MPH	Airspeed Indicator Marking
Never Exceed ( $V_{NE}$ )	180	200	Red Line
Caution Range	160-180	160-200	Yellow Arc
Maximum Structural Cruise ( $V_{NO}$ )	160	160	End of Green Arc
Normal Operating Range	54-160	54-160	Green Arc
Maneuvering ( $V_A$ ) at Gross Weight:			
Normal Category	121	121	None
Acrobatic Category	132	132	None

**NOTE**

- CAS - Calibrated Airspeed: This is indicated airspeed corrected for position and instrument error.
- IAS - Indicated airspeed assumes zero instrument error.
- $V_{NE}$  - Maximum safe airspeed which is not to be exceeded at any time.
- $V_{NO}$  - Not to be exceeded except in smooth air only and then with caution.
- $V_A$  - No full or abrupt longitudinal control movements allowed above this airspeed.

**POWERPLANT LIMITATIONS AND INSTRUMENT MARKINGS**

Model	Decathlon	Decathlon CS	Super Decathlon
Engine, Lycoming	AE10-320-E2B	AE10-320-E1B	AE10-360-H1A
Propeller	Fixed Pitch 74DM6S8	Constant Speed HC-C2YL-4/ C7663-4	Constant Speed HC-C2YR-4CF/ FC7666A-2
Fuel, Minimum Octane Rating (Approved For Continuous Use)	80/87 (100/130)	80/87 (100/130)	100/130
Tachometer (rpm)			
Normal Range (green arc)	1800-2700	1800-2700	500-2000 2250-2700
Avoid Continuous Operation (red arc)			2000-2250
Avoid Aerobatic Operation (red arc)			2600-2700
Maximum (red radial)	2700	2700	2700
Cylinder Head Temperature (°F)			
Normal Range (green arc)	90-500	90-500	90-500
Maximum (red radial)	500	500	500
Oil Temperature (°F)			
Normal Range (green arc)	100-245	100-245	100-245
Maximum (red radial)	245	245	245
Oil Pressure (psi)			
Normal Range (green arc)	60-100	60-100	60-100
Caution Range (yellow arc)	25-60	25-60	25-60
Maximum (red radial)	100	100	100
Minimum (red radial)	25	25	25
Fuel Pressure (psi)			
Normal Range (green arc)	12-45	12-45	14-45
Maximum (red radial)	45	45	45
Minimum (red radial)	12	12	14

## WEIGHT AND BALANCE LIMITS

	Decathlon Decathlon CS	Super Decathlon
Maximum Gross Weight	1800 Lbs.	1800 Lbs.
Center of Gravity Range		
Normal Category	+13.5 to +21.0 at 1800 Lbs.  +11.5 to +21.0 at 1550 Lbs. or Less  Straight Line Variation Between Points Given.	+13.5 to +18.5 at 1800 Lbs.  +11.5 to +18.5 at 1550 Lbs. or Less  Straight Line Variation Between Points Given.
Aerobatic Category	+13.5 to +18.5 at 1800 Lbs.  +11.5 to +18.5 at 1550 Lbs. or Less  Straight Line Variation Between Points Given.	+13.5 to +18.5 at 1800 Lbs.  +11.5 to +18.5 at 1550 Lbs. or Less  Straight Line Variation Between Points Given.
DATUM	Wing Leading Edge	Wing Leading Edge

## FLIGHT LOAD FACTORS (1800 Lbs. Gross Weight)

Category	Load Factor Limits	Accelerometer Marking
Normal	Positive + 5G Negative - 3G	Green Arc Green Arc
Acrobatic	Positive + 6G Negative - 5G	Red Line Red Line

### NOTE

Maximum load factors for Normal Category operations are shown by the ends of the green arc on the accelerometer. Load factors within the yellow arc up to the red radial lines are permitted only in the Acrobatic Category.



## KINDS OF OPERATION

Only VFR, day or night operations are approved with all required equipment operating as specified in FAR Part 91. Day VFR only operations are approved for Standard Decathlon with standard equipment (i.e. strobe lights and cabin light not installed).

Flight into known icing conditions is prohibited.

Crosswind landings have been demonstrated in 90<sup>0</sup> crosswinds up to 17 kts (20 mph).

## UNUSABLE FUEL

Any fuel remaining in the tanks when fuel gauge reads "0" or "E" (empty) cannot safely be used in flight.

Acrobatic Category--The inverted fuel header tank provides fuel for approximately 2.0 minutes of continuous inverted flight. The header tank will automatically refill after approximately one minute of upright, straight and level flight.

## INVERTED FLIGHT

Acrobatic Category--The header tank provides fuel for approximately two minutes of continuous inverted flight. Monitor oil pressure while inverted. Minimum oil pressure is 60 psi.

### WARNING

Fuel starvation may occur after a series of inverted maneuvers since the header tank may have had insufficient time to refill.

**MANEUVERS** (Refer to Section III Before Attempting  
Maneuvers)

Maneuvers	Recommended Entry Speed (IAS MPH)	
	Decathlon Decathlon CS	Super Decathlon
Loop (Normal or Inverted)	140	140
Immelmann	145	145
Hammerhead Turn	140	140
Hammerhead Turn (Inverted Entry & Exit)	140	140
Snap Roll (Normal or Inverted)	90	90
English Bunt	70	70
Vertical $\frac{1}{2}$ Slow Roll Up	160	160
Vertical Slow Roll Up (Super Decathlon Only)	---	180
Vertical Slow Roll Down	60	60
Slow or Barrel Roll	120	130
Outside Loop (Enter From The Top)	70	70
Horizontal Eight (Inside-Outside)	140	140
Spin (Normal or Inverted)	Stall	Stall

**NOTE**

Variations or combinations of the above maneuvers are approved provided that the speed or load factor limitations are not exceeded.

**WARNING**

Tail slides and Lomcevaks (tumbling maneuvers) are not approved

No full or abrupt use of flight controls is permitted above maneuvering speed.

## REQUIRED PLACARDS

See FAA Approved Airplane Flight Manual for placards required in a specific aircraft. The following placards represent a typical airplane.

### In Full View Of Pilot

Normal Category Airspeed Limits  
Maneuvering Speed 121 MPH (105 Knots) CAS  
Demonstrated Crosswind Velocity-20 MPH (17 Knots)

Solo From Front Seat Only. No Acrobatic Maneuvers, Including Spins, Approved In Normal Category. Day Or Night VFR Operation Only. Flight Into Known Icing Prohibited. To Recover From Normal Or Inverted Spin, Use Full Opposite Rudder and Neutralize Elevator.

This Airplane Must Be Operated As a Normal Or Acrobatic Category Airplane In Compliance With The Operating Limitations Stated In The Form Of Placards, Markings, And Manuals. Markings And Placards (Except Accelerometer Markings) Refer To Normal Category Only. See Airplane Flight Manual For Acrobatic Category Information, Weight and Balance Information, And Other Operating Limitations.

NO SMOKING (when ashtrays not installed)

### On Tachometer Face

Avoid 2000-2250  
Continuous Oper.

### In Baggage Compartment

Maximum BAGGAGE 100 Lbs.

## REQUIRED PLACARDS (cont'd)

### On Forward Left Side Window

Do Not Open Above 130 MPH

Alternate Emergency Exit  
Unlatch-Force Forward Portion Past Stop

### On Fuel Valve Control

Fuel  
40 Gal Useable  
Down "ON"

### On Emergency Door Release Handle

EMERGENCY DOOR RELEASE  
PULL PIN——PULL HANDLE

### Adjacent To Fuel Gauge

Fuel In Tank When Gauge Reads "E" (Empty)  
Cannot Be Safely Used In Flight

### Adjacent To Strobe Light Switch

W A R N I N G  
Turn Off Strobe Lights When Taxiing In  
Vicinity Of Other Aircraft, Or During  
Flight Through Cloud, Fog Or Haze.  
Standard Position Lights To Be On For  
All Night Operations.

## REQUIRED PLACARDS (cont'd)

On Front Seat Rear Leg (Adjustable Front Seat)

Rear Seat P/N 7-1500 Or  
7-1501 And Rear Control  
Stick P/N 4-1711 Req'd.  
With This Seat Install.

On Rear Control Stick

Rear Stick P/N 4-1711

On Rear Seat Front Leg

Rear Seat P/N 7-1500

or

Rear Seat P/N 7-1501

## SECTION II EMERGENCY PROCEDURE

### INDEX

GENERAL.....	2-1
ENGINE FIRE DURING START.....	2-2
ENGINE FIRE IN FLIGHT.....	2-2
ELECTRICAL FIRE.....	2-2
ALTERNATOR/ELECTRICAL FAILURE.....	2-3
ENGINE FAILURE ON TAKEOFF.....	2-3
ENGINE AIR RESTART.....	2-4
PARTIAL POWER LOSS/ROUGH RUNNING.....	2-4
ABNORMAL OIL PRESSURE/TEMPERATURE INDICATIONS..	2-4
LOSS OF PROPELLER CONTROL.....	2-5
PRECAUTIONARY LANDING APPROACH.....	2-5
FORCED LANDING (COMPLETE POWER FAILURE).....	2-6
DITCHING.....	2-6
STATIC SYSTEM FAILURE.....	2-7
SEVERE TURBULENCE.....	2-7
STALLS.....	2-7
SPINS.....	2-8
INFLIGHT OVERSTRESS.....	2-9
EMERGENCY EXIT/BAIL OUT.....	2-9

### GENERAL

This section covers the recommended procedures to follow during emergency and adverse flight conditions. As it is not possible to define every type of emergency that may occur, it is the pilot's responsibility to use sound judgement based on experience and knowledge of the aircraft to determine the best course of action.

#### NOTE

All airspeeds in this section are indicated airspeeds (IAS), unless stated otherwise.

Familiarization and practice of any emergency procedure must be done under the supervision of a qualified flight instructor under carefully controlled conditions. Refer to Section III prior to performing any maneuvers.

## ENGINE FIRE DURING START

If the fire is believed to be confined to intake or exhaust system (result of flooding engine):

- 1) Continue cranking engine with starter.
- 2) Mixture Control - IDLE CUT-OFF.
- 3) Throttle - FULL OPEN.
- 4) Inspect aircraft thoroughly for damage and cause prior to restart.

If fire persists or is not limited to intake or exhaust system:

- 1) Mixture Control - IDLE CUT-OFF.
- 2) Fuel Shut-Off Valve - OFF.
- 3) Electrical and Magneto Switches - ALL OFF.
- 4) Exit Aircraft.
- 5) Direct fire extinguisher through the bottom of the nose cowl or through the cowl access door.

## ENGINE FIRE IN FLIGHT

- 1) Mixture Control - IDLE CUT-OFF.
- 2) Fuel Shut-Off Valve - OFF.
- 3) Electrical and Magneto Switches - ALL OFF.
- 4) Cabin Heat - OFF Front and Rear.
- 5) Use hand fire extinguisher if available.
- 6) Land immediately using "Forced Landing Procedures".

## ELECTRICAL FIRE

An electrical fire is usually indicated by an odor of hot or burning insulation and wisps of smoke.

- 1) Electrical Switches - ALL OFF (leave magneto switches ON).
- 2) Air Vents/Windows - OPEN only if absolutely necessary for smoke removal and ventilation.
- 3) Use hand fire extinguisher if available and necessary.
- 4) If fire continues, land immediately.

If fire/smoke stops and electrical power is required for the remainder of the flight, turn the master switch ON, followed by the desired circuit switch. Allow a minute between turning on each switch in order that the faulty circuit may be located and switched OFF.

## ALTERNATOR/ELECTRICAL FAILURE

An alternator failure is indicated by a steady discharge on the ammeter.

- 1) Master Switch - CYCLE in attempt to reset the overvoltage relay.
- 2) If excessive battery discharge continues, turn OFF all nonessential electrical equipment to conserve battery power.
- 3) Land as soon as practical as the battery will furnish electrical power for a limited time only.

If only one circuit (e.g. Radio) appears to be inoperative, remove and replace the suspected fuse with a spare of the same amperage rating. The spare fuses are located above the regular fuses in use.

### NOTE

Engine operation is unaffected by a complete electrical system failure with the exception of the engine starter.

## ENGINE FAILURE ON TAKEOFF

If sufficient runway remains:

- 1) Throttle - CLOSED.
- 2) Land using brakes as required.

If airborne and insufficient runway remains for landing, select the most favorable landing area ahead. Attempt an engine restart if altitude permits using ENGINE AIR RESTART procedures.

If no restart is possible, land in preselected area using FORCED LANDING procedures.

### WARNING

Maintain flying speed at all times and do not attempt to turn back towards the runway unless sufficient altitude has been achieved.



## ENGINE AIR RESTART

- 1) Maintain Airspeed - 80 MPH minimum recommended.
- 2) Emergency Fuel Pump - ON.
- 3) Alternate Air - FULL HOT.
- 4) Mixture - FULL RICH or LEANED as required at high altitude.
- 5) Fuel Shut-Off Valve - CHECK ON.
- 6) Magneto Switches - BOTH ON (Up).
- 7) Propeller Control - FULL INCREASE (except Decathlon (Standard)).
- 8) If restart not possible, change throttle, mixture, primer settings in attempt to restart.
- 9) Follow "Forced Landing Procedure" if unable to restart.

### NOTE

The engine starter may be engaged in flight if the engine has stopped windmilling.

## PARTIAL POWER LOSS/ROUGH RUNNING

- 1) Follow the engine air restart procedures.
- 2) Land as soon as practical using "Precautionary Landing Approach" procedures.

Obstruction of the engine intake air may be indicated by a gradual power loss. Alternate air should be applied to the hot position and left in that position as long as the obstructed condition exists.

## ABNORMAL OIL PRESSURE/TEMPERATURE INDICATIONS

Oil pressure and temperature problems are usually related with one affecting the other. Before any drastic action is taken, cross check other engine instruments and control settings in an attempt to determine the source of the problem.

High oil temperature is generally a result of loss of oil, overheating (note CHT if available) or a malfunctioning oil cooler by-pass valve. If the situation remains unchecked, oil pressure usually drops resulting in possible engine damage. Power should be reduced while maintaining cruise airspeed; place mixture in FULL RICH position and land as soon as practical.

Little or no oil pressure is usually caused by a failed pressure relief valve, pump, loss of oil, clogged oil line, high oil temperature or a defective gauge. A landing should be made as soon as practical using a minimum power. Plan a "Precautionary Landing Approach" as complete engine failure is possible at any time.

## LOSS OF PROPELLER CONTROL (Except Decathlon(Standard))

In the event of loss of oil pressure to the propeller and/or propeller governor, the propeller will automatically go to the LOW RPM position. The throttle may be used with caution as necessary to climb or maintain level flight. A precautionary landing should be made as soon as practical.

### PRECAUTIONARY LANDING APPROACH

A precautionary landing approach should be used whenever power is still available, but a complete power failure is considered imminent. Maintain a higher and closer pattern than normal to remain well within gliding distance of the intended touch down point. Use the normal landing procedures in addition:

- 1) Airspeed - 75 MPH recommended (70 MPH minimum).
- 2) Throttle - CLOSED when in gliding distance to runway.
- 3) Propeller Control - FULL INCREASE (except Decathlon (Standard)).
- 4) Slip the Aircraft to Increase Rate of Descent as Required.

## **FORCED LANDING (Complete Power Failure)**

If the engine cannot be restarted in flight, trim the aircraft to the recommended glide speed. Remain within gliding distance of the intended point of landing. Maintain a higher and closer pattern than normal making allowance for wind.

Additional altitude can be lost by slipping the aircraft. Diving the aircraft in an attempt to lose altitude will only increase the required landing distance.

- 1) Airspeed - Maintain 75 MPH.
- 2) Mixture - IDLE CUT-OFF.
- 3) Fuel Shut-Off Valve - OFF.
- 4) Master Switch - ON.
- 5) Radio - MAYDAY 121.5 MHz.
- 6) Attempt to position the aircraft approximately 1000 feet above ground level (AGL) over the intended point of landing or 500 feet when downwind and abeam the intended point of landing.
- 7) Electrical Switches - ALL OFF.
- 8) On Final Approach - Airspeed 75 MPH (70 MPH minimum).
- 9) Touchdown with minimum airspeed (three point full stall) if landing on rough terrain.

### **NOTE**

If necessary, after aircraft has come to a complete stop, remove and activate the emergency locator transmitter from the aircraft for increased transmitting range.

## **DITCHING**

Should it become necessary to make a forced landing over water, follow the "Forced Landing Procedures" in addition to the following:

- 1) Cabin Side Door - JETTISON.
- 2) Land into wind if high winds are evident or parallel to swells with calm winds.
- 3) Contact the water with a nose high attitude.
- 4) DO NOT STALL prior to touchdown.
- 5) After coming to complete stop - EXIT AIRCRAFT.

### **NOTE**

Aircraft cannot be depended on to provide floatation after contacting the water.

## STATIC SYSTEM FAILURE

A malfunction in the static system will affect the airspeed, altimeter and vertical speed indicator and may be a result of an obstructed static opening. An alternate static source can be provided from within the cabin by breaking the glass in the airspeed, altimeter or rate of climb instrument face.

### WARNING

With an alternate static source provided from within the cabin, subtract approximately 65 feet from indicated altitude and 10 MPH from indicated airspeed.

## SEVERE TURBULENCE

In severe turbulence do not exceed 121 mph IAS. Maintain a constant nose attitude rather than flying by reference to the altimeter and airspeed indicator.

## STALLS

The Decathlon stall characteristics are conventional. The stall warning horn will precede the stall by 5 - 10 MPH depending on the amount of power used. There is very little aerodynamic buffeting preceding the stall.

Aileron control in a power on stall is marginal. Large aileron deflections will aggravate a near stalled condition and the use is not recommended to maintain lateral control. The rudder is very effective for maintaining lateral control in a stalled condition with the ailerons placed in the neutral position. To recover from a stall, proceed as follows:

- 1) LOWER NOSE and add FULL POWER simultaneously.
- 2) Use the rudder to maintain lateral control.

### WARNING

Do not allow aircraft to stall unless sufficient altitude exists for safe recovery.

## SPINS

Normal or inverted spins are approved in this aircraft when flown in the acrobatic category. Spins are prohibited in the normal category. Use the following recovery procedure for a normal spin.

### WARNING

Do not allow aircraft to spin unless sufficient altitude exists for safe recovery.

- 1) Throttle - CLOSED.
- 2) Ailerons - NEUTRAL POSITION.
- 3) Elevator - POSITIVE FORWARD TO NEUTRAL (free release of elevator control is not adequate for recovery).
- 4) Rudder - FULL DEFLECTION in the opposite direction to the rotation.
- 5) Rudder - NEUTRALIZE when rotation stops and positive control and flying speed is restored.
- 6) Nose Attitude - RAISE smoothly to level flight attitude.
- 7) Throttle - only after recovery from diving altitude, then as required.

Use the following recovery procedures for inverted spins.

- 1) Throttle - CLOSED.
- 2) Ailerons - NEUTRAL POSITION.
- 3) Elevator - POSITIVE REARWARD TO NEUTRAL (free release of elevator control is not adequate for recovery).
- 4) Rudder - FULL DEFLECTION in the opposite direction to the rotation.
- 5) Rudder - NEUTRALIZE when rotation stops and positive control and flying speed is restored.
- 6) Nose Attitude - RAISE smoothly to normal upright level flight attitude.
- 7) Throttle - only after recovery from diving attitude, then as required.

### WARNING

During the spin recovery, the airspeed will build very rapidly with a nose low attitude. Smooth but positive recovery from the dive is important to avoid an overspeed condition. Do not use full or abrupt elevator control movements after recovery to avoid secondary stall-spin.

## INFLIGHT OVERSTRESS

An inflight overstress can occur if either airspeed and/or load factor limits are exceeded or if controls are misused. Aerobatics should be terminated immediately. Fly at a reduced airspeed (70-80 MPH) to a suitable landing point. DO NOT under any circumstances, make large control movements or subject the aircraft to additional "g" loadings above that required for straight and level flight, and gentle turns. After landing, the aircraft should be inspected for damage by a qualified mechanic prior to the next flight.

## EMERGENCY EXIT/BAIL OUT

- 1) Throttle - CLOSED.
- 2) Jettison the Door.
- 3) Use the cabin door frame for support. Dive straight out and slightly aft of the wing struts.
- 4) Use left side window as alternate exit if you are unable to exit through the door. Force forward portion of window past stop to open as alternate exit window.
- 5) Parachute - Open immediately when clear of aircraft (preflight and familiarize yourself with operating procedures of the parachute before the flight).

# SECTION III

## NORMAL OPERATING PROCEDURE

### INDEX

GENERAL.....	3-1
PREFLIGHT INSPECTION.....	3-2
COLD WEATHER OPERATION.....	3-5
BEFORE STARTING.....	3-6
STARTING.....	3-7
TAXI.....	3-8
BEFORE TAKEOFF.....	3-9
TAKEOFF-NORMAL.....	3-10
TAKEOFF-OBSTACLE.....	3-11
TAKEOFF-SOFT FIELD.....	3-11
CLIMB.....	3-12
CRUISE.....	3-13
STALLS.....	3-13
AEROBATICS.....	3-14
DESCENT.....	3-19
LANDING-NORMAL.....	3-20
LANDING-OBSTACLE/SHORT FIELD.....	3-21
LANDING-SOFT FIELD.....	3-21
SHUTDOWN.....	3-22
GROUND HANDLING.....	3-22

### GENERAL

This section covers all recommended normal operating procedures using a checklist format whenever possible with additional information if further explanation is required.

#### NOTE

All airspeeds in this section are indicated airspeeds (IAS), unless stated otherwise.

## PREFLIGHT INSPECTION

The following inspection should be conducted prior to each flight. The inspection is broken down by area; the following circled numbers correlate with those presented in Figure 3-1.

This checklist emphasizes areas of importance. However, the preflight inspection should also consist of a thorough look at the aircraft for general condition and airworthiness.

### ① Cabin

- a) Cabin Door and Release Mechanism - CHECK condition, security.
- b) Flight Controls - CHECK freedom of movement.
- c) Magneto and Electrical Switches - OFF (check operation of lights if required and stall warning system with respective switches ON).
- d) Fuel Quantity Gauge - CHECK quantity.
- e) Fuel Shut-Off Valve - ON.
- f) Seat Belts - CHECK CONDITION, SECURE rear belt and harness if not in use (see Figure 3-2).
- g) Emergency Locator Transmitter - ARMED.
- h) Before Aerobatic Flights, Remove Loose Articles and Equipment - insure the cabin is clean.

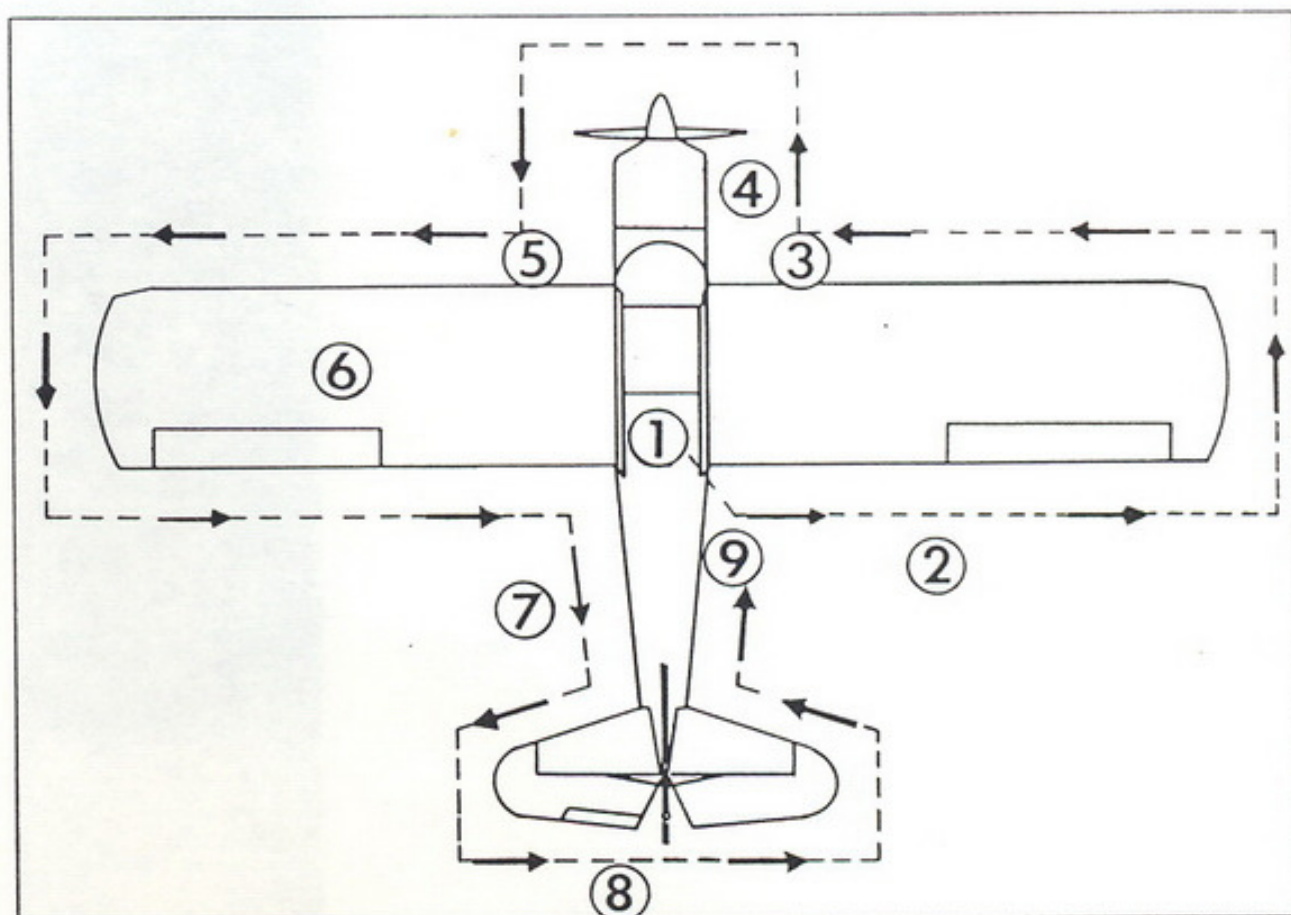

FIGURE 3-1 PREFLIGHT INSPECTION



WEARING FRONT SEAT ACRO HARNESS

ACRO HARNESS ASSEMBLY INCLUDES:

- 1-double shoulder harness with retractor reel or manual adjustors;
- 2-lap belt (left and right portions);
- 3-groin strap;
- 4-five point buckle.

INSTALLATION ACRO HARNESS:

- 1-extend shoulder harness;
- 2-adjust over shoulders and couple to buckle;
- 3-allow shoulder harness reel to retract or adjust harness placing the buckle above the waist but below the chest;
- 4-attach both lap belt portions to buckle and tighten.

**WARNING**

Acro harness does not provide for forward restraint crash protection and therefore should always be used with primary lap belt and shoulder strap.

DO NOT ALLOW ACRO HARNESS TO RUN UP BEHIND THE FRONT SEAT BACK WHERE IT MAY POSSIBLY INTERFERE WITH REAR STICK MOVEMENT.

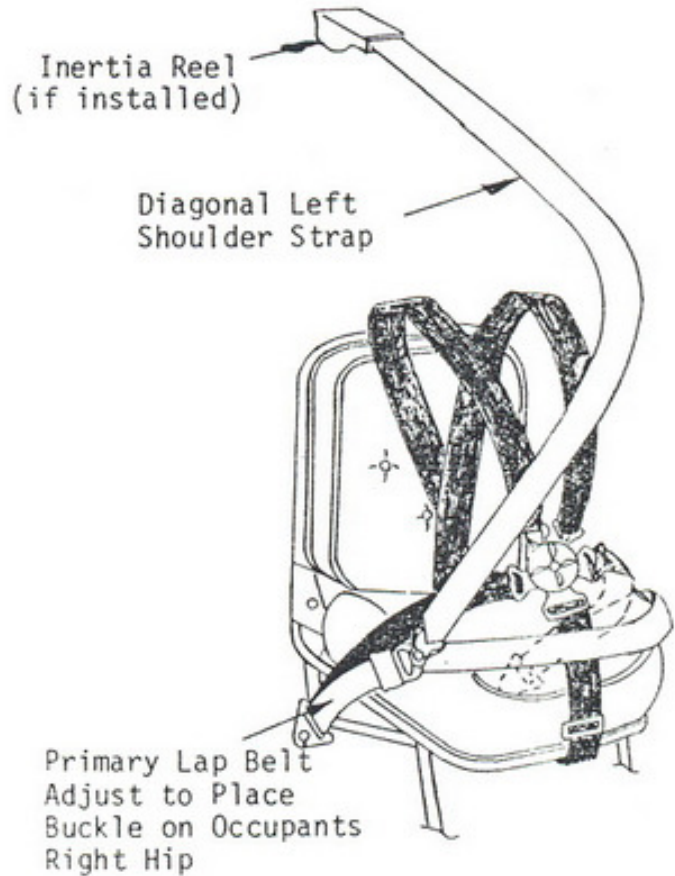

STOWING FRONT SEAT ACRO HARNESS

- 1-remove back cushion;
- 2-lay shoulder harness over seat back frame;
- 3-replace back cushion;
- 4-lift forward edge of bottom cushion;
- 5-attach lap belts to buckle and adjust and tighten with buckle at forward edge of seat frame;
- 6-insure that belts do not interfere with rudder pedal operation;
- 7-replace forward edge of cushion.

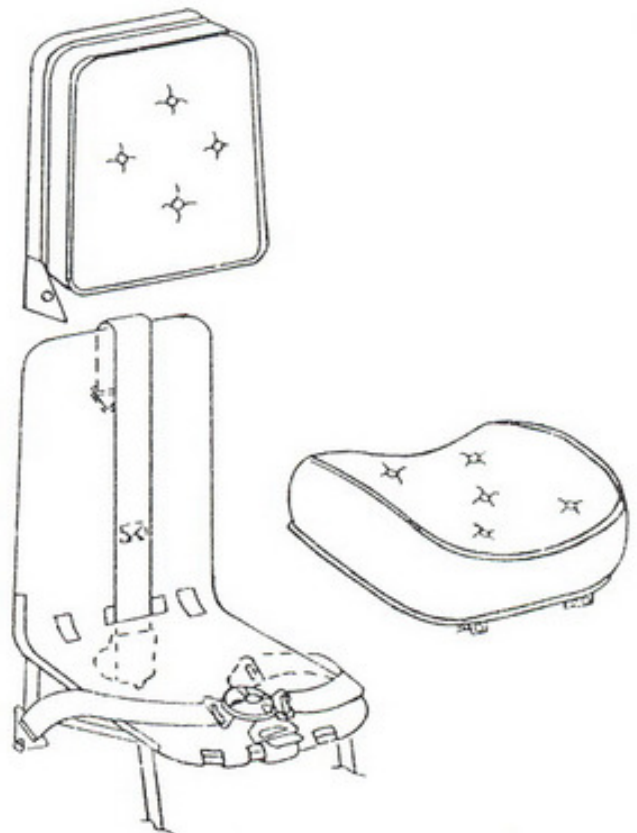

FIGURE 3-2 SEAT BELTS/ACRO HARNESS

## PREFLIGHT INSPECTION (cont'd)

### ② Right Wing

- a) Wing Root Fairing and Greenhouse Roof - CHECK secure.
- b) Aileron - CHECK condition, freedom of movement, security
- c) Wing Tip and Light - CHECK condition.
- d) During preflight inspection performed by pilot
  - 1) Inspect the front and rear lift struts for straightness, dents and other damage,
  - 2) Check strut drain holes to insure that they are not plugged and the struts do not contain water,
  - 3) If either of the above conditions is found, contact an authorized aircraft mechanic to determine aircraft airworthiness.
- e) Tie-Down - REMOVE.
- f) Fuel - CHECK quantity, cap secure.

### ③ Right Main Gear

- a) Chocks - REMOVE.
- b) Tires - CHECK condition, inflation.
- c) Brakes - CHECK condition, leakage.
- d) Wheel Fairing - CHECK condition, security.

### ④ Nose Section

- a) Windshield - CHECK condition, cleanliness.
- b) Oil - CHECK quantity, dip stick secure.
- c) Fuel - DRAIN gascolator and sample fuel for contamination and color, CHECK leakage.
- d) Engine Compartment - CHECK condition, leakage, etc.
- e) Cowling and Inspection Door - CHECK condition, security.
- f) Propeller and Spinner - CHECK condition, security.
- g) Air Filter - CHECK condition.
- h) Landing Light - CHECK condition.

### ⑤ Left Main Gear: Same as right main gear.

### ⑥ Left Wing

- a) Same as right wing, in addition.
- b) Fuel Vent - CHECK unobstructed.
- c) Stall Warning Vane - CHECK freedom of movement.
- d) Pitot Tube - CHECK to insure it is unobstructed.

## PREFLIGHT INSPECTION (cont'd)

### ⑦ Fuselage (Left Side)

- a) Fabric - CHECK condition, oil, battery acid leakage, etc.
- b) Windows - CHECK condition, cleanliness, condition and security.
- c) Fuel Belly Drain - DRAIN, CHECK and sample fuel for contamination and color, CHECK leakage.
- d) Radio Antenna(s) - CHECK secure.
- e) Static Source - CHECK to insure it is unobstructed.

### ⑧ Empennage

- a) Horizontal Stabilizer and Brace Wires - CHECK condition, security.
- b) Vertical Stabilizer and Tail Light - CHECK condition.
- c) Elevator, Trim Tab and Rudder - CHECK condition, freedom of movement, security.
- d) Tail Wheel - CHECK condition, inflation, security.
- e) Tie-Down - REMOVE.

### ⑨ Fuselage (Right Side)

- a) Same as fuselage left side (no fuel drain on right side).

## COLD WEATHER OPERATIONS

The following operating practices are recommended for cold weather operations (below 20° F).

Engine preheat (if aircraft is not kept in a heated hangar): Prior to starting, the engine compartment should be thoroughly preheated. Should moisture be present in the oil or breather system, preheating will assure that ice is not blocking passages or lines. The preheat is best accomplished with a large volume of warm air (200° F maximum) directed into the engine compartment through the oil access door. This preheat should be continued long enough to assure that the oil and breather system components have been thoroughly heated. This preheat time will be dependent upon the volume and temperature of the preheat air.

Care should be taken during preheating that the preheat air is not above 200° F as many components in the engine compartment or the cowling may be damaged or scorched.

## COLD WEATHER OPERATION (cont'd)

It is important to use the proper viscosity engine oil and to run the engine sufficiently long to bring the engine oil temperature and pressure to the normal operating range. Under some extreme winter conditions oil temperature may not indicate on the oil temperature gauge until airborne; it is very important that oil pressure be within the green arc prior to run-up and takeoff regardless of oil temperature. This is particularly important as the Decathlon utilizes the Christen inverted oil system. This system has external oil supply lines. Cold oil will not circulate well in cold lines and other engine parts, so the flow of oil from the engine sump through the external hoses and components of the Christen System will be severely impeded until the oil, the engine and all external system parts are warmed up.

The engine should be operated such that the oil temperature is maintained as high as is practical but not exceeding red line. Extended ground warm-up will help increase oil temperatures. These warm-up runs are best accomplished at 1500 to 2000 RPM. Extended periods of operation at low throttle settings should be avoided during flight as these operations lower oil temperatures.

It is recommended that the 25-hour oil change interval be observed and that the oil and breather lines be checked for moisture accumulation during the oil change. It is also recommended that an inspection be made for moisture accumulation at five to ten operating hour intervals. See Section VII for maintenance details.

### BEFORE STARTING

- 1) Seat Belts/Shoulder Harness - FASTENED and adjusted (see Figure 3-2).
- 2) Fuel Shut-Off Valve - ON.
- 3) Brakes - SET.
- 4) Electrical Switches - OFF.
- 5) Cabin Door - CLOSED (windows as desired).
- 6) Flight Controls - CHECK for free and correct movement.
- 7) Radios - OFF.

Set the parking brake by depressing the brake pedals and pulling the park brake knob located under the far right side of the instrument panel.

**STARTING**

- 1) Airplane Preflight Inspection - COMPLETE.
- 2) Cabin Door - SECURED.
- 3) Seat Belts and Shoulder Harnesses - FASTENED and adjusted or STOWED.
- 4) Fuel Shut-Off Valve - ON.
- 5) Brakes - SET.
- 6) Propeller Control - FULL INCREASE (except Decathlon (Standard)).
- 7) Alternate Air - Cold.
- 8) Electrical and Radio Switches - OFF.
- 9) Master Switch - ON.
- 10) Engine Prime (as required)
  - a) Mixture - FULL RICH.
  - b) Throttle - 1/4 to 1/2 inch OPEN.
  - c) Electric Fuel Pump - ON until fuel pressure is indicated, then OFF.
- 11) Mixture - IDLE CUT-OFF.
- 12) Throttle - 1/2 to 1 inch OPEN.
- 13) Magneto Switches - BOTH ON.
- 14) Insure Propeller and Propeller Blast Area is CLEAR.
- 15) Starter - ENGAGE, release after engine fires.
- 16) Mixture - FULL RICH after engine fires.
- 17) Throttle - 1000 to 1200 RPM.
- 18) Oil Pressure - CHECK, must indicate pressure within 30 seconds maximum.
- 19) Electrical and Radio Switches - AS DESIRED.
- 20) Brakes - release when ready to taxi.

The amount of fuel priming will vary with each engine and temperature condition. If the engine is warm, little or no prime is required.

**CAUTION**

Do not overprime due to the resulting fire hazard.

To clear an engine that has been flooded due to excessive priming, proceed as follows:

- 1) Electric Fuel Pump - OFF.
- 2) Mixture - IDLE CUT-OFF.
- 3) Throttle - FULL OPEN.
- 4) Magneto Switches - OFF.
- 5) Starter - ENGAGE for several propeller revolutions.
- 6) Repeat normal starting procedures using no prime.

**CAUTION**

Limit the use of the starter to 30 seconds duration maximum with a two minute cooling off period between each starter engagement.

## STARTING (cont'd)

During ground operation, the mixture should be FULL RICH and the carburetor/alternate air COLD to insure good engine cooling and filtered air. Prolonged idle below 1000 RPM is not recommended due to plug fouling and insufficient cooling air when the aircraft is not in motion.

### WARNING

Do not attempt to turn over and/or start the engine by hand unless you have had proper instruction and experience. If pulling the propeller through by hand is necessary, be sure the master and magnetos are in the OFF position and the throttle closed. Have a pilot at the controls and chock/tie down the aircraft. When pulling the propeller through by hand, treat it as if the ignition switch is turned on. A loose or broken ground wire on either magneto could cause the engine to fire.

## TAXI

Taxi operations during high winds requires the conventional use of the flight controls. With a head wind or quartering head wind, place the control stick full aft and into the wind. With a tail wind or quartering tail wind, use the opposite procedures. Cautious use of the wheel brakes in conjunction with the rudder will assist the pilot in maintaining directional control.

**BEFORE TAKEOFF**

- 1) Brakes - SET.
- 2) Flight Controls - CHECK freedom of movement, proper operation.
- 3) Elevator Trim - SET takeoff position.
- 4) Flight Instruments/Radio(s) - CHECK and SET.
- 5) Check Master Switch - ON.
- 6) Fuel Shut-Off Valve - ON.
- 7) Mixture - FULL RICH (lean as required for high altitude).
- 8) Engine Instruments - CHECK normal indications.
- 9) Engine Run-Up - 1800 RPM (Elevator Control - FULL BACK)
  - a) Magnetos - CHECK (175 RPM maximum drop, 50 RPM maximum differential) return both switches to ON,
  - b) Propeller (except Decathlon (Standard)) - CHECK operation (full decrease until RPM drop of 300 to 500), return to high RPM position,
  - c) Alternate Air - CHECK operation then return to COLD position,
  - d) Engine Instruments - within green arc,
  - e) Throttle - 1000 RPM.
- 10) Electric Fuel Pump - ON.
- 11) Cabin Door and Windows - CLOSED and LATCHED.
- 12) Seat Belts/Shoulder Harness - FASTENED and adjusted.
- 13) Brakes - release when ready for takeoff, check park brake full OFF.

Engine warm-up should be conducted at 1000 to 1200 RPM. High power operation (above 2200 RPM) and engine run-up should be made into the wind and kept to a minimum especially during high temperature conditions. The stick should also be held full aft to prevent the possibility of the aircraft nosing over. The magneto check is run at 1800 RPM using the BOTH-LEFT-BOTH-RIGHT-BOTH sequence. Maximum RPM drop on each magneto is not to exceed 175 RPM and the differential between mags should not exceed 50 RPM. The alternate air and propeller control should be checked for operation at this time. To check prop control, pull vernier control from full increase RPM to full decrease until a 300 to 500 RPM drop is noted, then return to full increase. Avoid using alternate air on the ground. With the alternate air selected, induction air is not filtered and abrasive dirt particles can enter the engine.

## TAKEOFF-NORMAL

- 1) Throttle - FULL OPEN applying smoothly.
- 2) Engine Instruments - CHECK normal indications and satisfactory takeoff power.
- 3) Attitude - RAISE TAIL.
- 4) Lift-Off - 55-60 MPH.
- 5) Climb - 75-80 MPH.

Takeoff characteristics are conventional for tail-wheel aircraft. It is recommended to raise the tail with the elevator during the takeoff roll for better forward visibility and directional control. Transition into flight with a smooth but positive rotation. After lift-off, allow aircraft to accelerate to desired climb speed.

### CAUTION

On the ground in the level flight attitude, the wheel brakes are very sensitive. It is recommended that directional control be maintained with the use of the rudder only.

Check full-throttle engine operation early in the takeoff run. The takeoff should be discontinued if there are any signs of rough engine operation or sluggish engine acceleration.

During crosswind conditions, place the control stick into the wind (up wind aileron UP) and assume a tail high attitude with the elevator to prevent drifting or premature lift-off.

High altitude takeoffs are accomplished by using the normal takeoff procedures with the addition of leaning the mixture control for smooth engine operation and allowing for the effects of density altitude.



## TAKEOFF - OBSTACLE

During an obstacle takeoff, use the Normal Takeoff procedures with the following exceptions (refer to Section IV for appropriate distances):

- 1) Apply full power rapidly but smoothly.
- 2) Accelerate in three-point (tail down) attitude.
- 3) Maintain following speeds until clear of 50 ft. obstacle.

Decathlon (Standard)---61 mph IAS  
Decathlon CS-----60 mph IAS  
Super Decathlon-----58 mph IAS

### WARNING

The aircraft must be pitched forward to a safe power-off speed should a power failure occur during climb-out; failure to respond immediately may result in a stall at low altitude.

## TAKEOFF - SOFT FIELD

For soft field takeoff, use the Normal Takeoff procedures with the following exceptions:

- 1) Attitude - TAIL LOW but clear of ground.
- 2) Lift-Off - as soon as possible.
- 3) After Lift-Off - LEVEL FLIGHT to obtain safe margin of airspeed prior to climb.

### WARNING

Good pilot judgement and experience are required to determine suitability of a soft field for safe takeoff operation.

The aircraft will lift-off at very low IAS, however, continued climb-out below takeoff-obstacle speed is not recommended.

Be sure to account for the additional takeoff roll and distance to clear an obstacle resulting from the added drag of a soft field. Good pilot judgement is required to make these allowances as it is not possible to tabulate such corrections due to their large variability.

**CLIMB**

- 1) Throttle - FULL OPEN.
- 2) Propeller Control - FULL INCREASE (except Decathlon (Standard)).
- 3) Mixture - lean only as required to maintain smooth engine operation.
- 4) Airspeed - 75-80 MPH.
- 5) Electric Fuel Pump - OFF after safe altitude has been obtained.

For maximum performance climbs, use full throttle and the following speeds.

Model	Decathlon (Standard) (mph IAS)	Decathlon CS (mph IAS)	Super Decathlon (mph IAS)
Best Rate of Climb ( $V_y$ )	76	73	80
Best Angle of Climb ( $V_x$ )	61	60	58

If best rate of climb (or best angle of climb) is not required, a climb speed between 80 and 90 MPH will provide good forward visibility (and engine cooling in a warm climate). The mixture should be full rich; lean only as required to maintain smooth engine operation.

**NOTE**

Monitor fuel pressure gauge when switching electric fuel pump off to insure continuous fuel pressure "in the green" with electric fuel pump off.

## CRUISE

- 1) Level-Off - TRIM.
- 2) Airspeed - ACCELERATE to desired cruise airspeed.
- 3) Power - SET to cruise power.
- 4) Mixture - LEAN when below 75% power.

The fuel mixture should be leaned at any altitude when below 75% of maximum power. Lean to peak EGT if equipped. If no EGT is installed, lean until engine roughness or loss of power is noted then enrich until smooth.

### WARNING

Range and endurance information is based on a properly leaned fuel mixture. Failure to lean the fuel mixture will increase fuel consumption appreciably.

Continuous use of alternate air during cruising flight decreases engine efficiency. Unless conditions are severe, do not cruise with alternate air on. When selecting alternate air, do so slowly to the full-on position and only for a few seconds at intervals to determine if ice may have developed on the air intake filter. The Decathlon is not approved for flight into known icing conditions.

## STALLS

The stall characteristics of the Decathlon are conventional. For stall speeds at various angles of bank, refer to stall speed table in Section IV.

### WARNING

Stall aircraft only if sufficient altitude exists for safe recovery.

## AEROBATICS

The Decathlon is certified in the Aerobatic Category. Flying aerobatics places a much greater demand on the pilot's ability, knowledge of the aircraft and current regulations. The following information is provided to make aerobatic flying enjoyable, with the utmost emphasis on safety. However, the pilot should not attempt aerobatics unless he has received training by an instructor qualified for aerobatic instruction.

Federal Aviation Regulations (FARs) Part 91.71 specify the airspace and altitudes required for aerobatic flight. Altitude may be the pilot's greatest safety factor and should not be compromised. The wearing of approved parachutes is specified in Part 91.15. It is strongly recommended that parachutes always be worn during aerobatic flight.

Bellanca Aircraft Corporation also recommends that pilots utilizing aircraft for aerobatics read the Advisory Circular 91-48: Acrobatics-Precision Flying With A Purpose. This advisory circular provides information to persons who are interested in aerobatics to improve their piloting skills as recreation, sport, or as a competitive activity. It also discusses Federal Aviation Regulations pertaining to aerobatic aircraft airworthiness considerations, aerobatic instruction, operations and aerobatic flight safety.

Know and respect your airplane's structural limitations. The Decathlon structure is designed to withstand a maximum load factor of +6 G's and -5 G's at a maximum gross weight of 1800 lbs.

### WARNING

Do not exceed +6.0 "g" positive load factor or -5.0 "g" negative load factor. Do not perform aerobatics in turbulent air.

Never exceed the above load factors regardless of weight. Flying at reduced weights improves performance. Flying above 1800 lbs. is not only prohibited but also greatly increases the chances of a serious overstress resulting in damage or possible structural failure.

The rear center of gravity (C.G.) limit is critical for aerobatic flight. This limit is specified in Section I and V. Baggage is NOT allowed during aerobatic flight. Also, all personal equipment (charts, flight computer, etc.) should be properly secured.

## AEROBATICS (cont'd)

A person learning to fly must be taught how to do so safely. The same holds true for a pilot learning aerobatics. To attempt an aerobatic maneuver with no prior aerobatic instruction is extremely dangerous and NOT recommended.

Aerobatic flight places a greater demand on both the pilot and aircraft. A thorough preflight inspection/evaluation for both is considered essential. The pilot must know and abide by the limitations of the aircraft and his own personal limitations as well. Do not do aerobatics unless you are in good physical condition--not when you have a hangover, a cold or any other illness. If you are not in good condition, your reaction time is increased and your tolerance to G-loading is decreased. The FAA Approved Airplane Flight Manual has information concerning aerobatic limits and maneuvers and should be consulted.

Watch for other traffic while doing aerobatics. Perform a 90 degree clearing turn in each direction before beginning, checking for traffic all around the airplane. See Part 91 of the Federal Air Regulations for airspace in which aerobatics are prohibited.

At the completion of the flight, a post-flight inspection of the aircraft should also be conducted. If any discrepancies or doubts exist that concern airworthiness, consult a mechanic prior to the next flight.

Oil pressure during inverted flight may normally be 5 to 10 lbs. less than the oil pressure during normal flight. During the transition from normal to inverted flight and from inverted to normal flight, an oil pressure fluctuation may be indicated on the oil pressure gauge. This fluctuation is normally 20-40 psi and lasts about one second after which the normal oil pressure should be maintained.

Oil quantities in excess of normal oil level may be lost during the aerobatic sequence, but once the normal level is reached, oil losses should be small. The oil capacity is 8 quarts, but normal oil level is between 6 and 7 quarts. Oil should be added when the level falls below 6 quarts. Steep climbing-diving vertical attitudes or knife-edge flight may cause interruption of the oil pressure and/or loss of oil through the breather.

It is important to monitor the oil pressure during aerobatic flight. This is especially important when operating in extremely cold weather. Inadequate warm-up of the oil system components could cause impeded operation and inadequate oil pressure in the inverted position.

## **AEROBATICS (cont'd)**

Extended inverted flight or a sequence of maneuvers involving a large percent of negative "g" maneuvers may exhaust the inverted fuel supply causing loss of fuel pressure and power. At the first signs of fuel pressure loss or engine roughness, assume normal flight which will assure normal fuel flow and will automatically refill the inverted fuel supply.

### **NOTE**

Continuous inverted flight at full power will exhaust inverted fuel supply in approximately two minutes. Approximately one minute of positive "g" conditions is required to completely refill the inverted fuel supply.

### **WARNING**

Complete loss of fuel flow and power, caused by depletion of inverted fuel supply, may result in an interruption of power for up to 10 seconds after return to normal flight. AVOID THIS CONDITION UNLESS SUFFICIENT ALTITUDE INSURES SAFE RESTART.

The approved aerobatic maneuvers are presented in Section I along with recommended entry speeds. The following information and arrest symbols are presented to assist a properly trained aerobatic pilot perform the maneuvers shown. They do not include all procedures necessary to properly complete the maneuver and should therefore not be used in lieu of appropriate aerobatic flight instructions.

Variations or combinations of the approved aerobatic maneuvers are also approved provided the speed and load factor limitations are not exceeded.

### **WARNING**

Tail slides and Lomcevaks (tumbling maneuvers) are NOT APPROVED. Do not attempt any aerobatic maneuver without proper instruction and checkout.

## AEROBATICS (cont'd)

LOOP-NORMAL OR INVERTED (OUTSIDE)

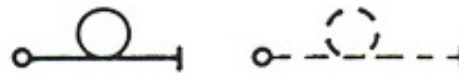

Enter the maneuver at 140 mph with about 3.5 to 4.0 "g"\* load factor. Speed at the top of the loop should be about 40-50 mph. Exit the loop with 3.5 to 4.0 "g"\* load factor.

IMMELMANN



Enter the maneuver at 140 to 145 with about 4.0 "g"\* pull up. Speed at the top should be 55-65 mph. Perform 1/2 slow roll at the top.

HAMMERHEAD TURN

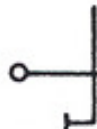

Enter the maneuver at 140 mph with 4.0 to 4.5 "g"\* pull up. Speed at the top before the turn (or pivot) should be about 40-50 mph. Exit with 4.0 to 4.5 "g"\* pull out and approximately 140 mph.

SNAP ROLL-NORMAL OR INVERTED (OUTSIDE)



Enter with power at 90 mph. Do not use full or abrupt use of flight controls above maneuvering speed.

ENGLISH BUNT

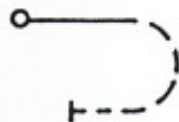

Enter the maneuver at 60-70 mph with a steadily increasing push-over to -3.5 to -4.0 "g's"\*. Exit maneuver inverted at 140-150 mph.

VERTICAL 1/2 SLOW ROLL UP

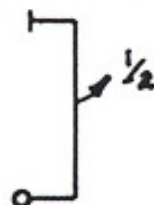

Enter the maneuver at approximately 160 mph using a 4.0 to 4.5 "g"\* pull up. CAUTION: Flight above  $V_{NO}$  (160 mph CAS) in smooth air only. Exit with push-over to level flight.

\*See WARNING Page 3-19.

## AEROBATICS (cont'd)

### VERTICAL SLOW ROLL UP (SUPER DECATHLON ONLY)



Enter the maneuver at 180 mph, using a +4.5 "g"\* pull up. CAUTION: Flight above  $V_{NO}$  (160 mph CAS) in smooth air only. Exit with push-over to level flight.

### VERTICAL SLOW ROLL DOWN



Enter the maneuver at approximately 60 mph and push-over to vertical down. Exit with approximately 4.5 "g"\* and 150 mph.

### SLOW OR BARREL ROLL



Enter the maneuver at 120 to 130 mph. Do not use full or abrupt use of flight controls above maneuvering speed.

### OUTSIDE LOOP (ENTER FROM THE TOP)

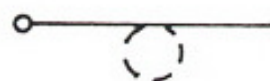

Enter the maneuver at 60-70 mph with steadily increasing push-over to -3.5 to -4.0 "g"\* at the bottom of the loop. Speed at the bottom should be approximately 140 mph. Continue -3.5 to -4.0 "g"\* push through the bottom of the loop. Steadily decrease negative load factor to 1 "g" at the top of the loop.

### HORIZONTAL EIGHT INSIDE-OUTSIDE



Enter the first half of the maneuver at 140 mph with about +4.0 "g"\* pull up. Enter the second half of the maneuver from about 140 mph with a -3.5 to -4.0 "g"\* negative load factor.

### HAMMERHEAD TURN (INVERTED ENTRY AND EXIT)

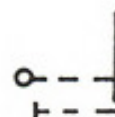

Enter the maneuver at about 140 mph with a -3.5 to -4.0 "g" push. The speed at the top before the turn (or pivot) is approximately 40-50 mph. Exit from vertical down with -3.5 to -4.0 "g"\* push to level flight inverted.

\*See WARNING Page 3-19.



**AEROBATICS (cont'd)**

## NORMAL SPINS

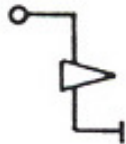

Enter from normal stall, power off with full aft stick and full rudder in desired direction of spin. Maintain spin with full pro spin control until 1/4 to 1/2 spin prior to recovery heading. Recover with positive movement of stick to neutral position and full opposite rudder. Hold pro recovery control until rotation stops and positive control and flying speed is restored. Then neutralize rudder and smoothly recover from the dive\* to level flight. Free release of controls is not adequate for spin recovery. Positive movement of the controls by the pilot is required.

**WARNING**

Spin aircraft only if sufficient altitude exists for safe recovery.

## INVERTED SPINS



Enter from inverted stall power off with full forward stick and full rudder in the direction of desired spin. Maintain with full pro spin controls until 1/4 to 1/2 turn prior to recovery heading. Recover with positive movement of stick to neutral position and full opposite rudder. Hold pro-recovery controls until rotation stops and positive control and flying speed is restored. Then neutralize rudder and smoothly recover from dive\* to level flight. Free release of controls is not adequate for spin recovery. Positive movement of the controls by the pilot is required.

**\*WARNING**

Do not apply full or abrupt use of flight controls above maneuvering speed. Proper use and application of controls and maneuvering load factors are essential to speed control. Improper and/or inadequate application of maneuvering load factors may result in rapid speed buildup resulting in unsafe flight situations.

**DESCENT**

- 1) Mixture - FULL RICH.
- 2) Throttle - REDUCE as desired.
- 3) Airspeed - AS DESIRED.

The descent should be made with enough power to maintain cylinder head oil temperatures in green arc. If possible, avoid windmilling the engine with the propeller by reducing airspeed or increasing power.

## LANDING - NORMAL

- 1) Seat and Shoulder Harness - FASTENED.
- 2) Propeller - FULL increase.
- 3) Mixture - RICH.
- 4) Electric Fuel Pump - ON.
- 5) Brakes - CHECK FIRM (Park Brake - OFF).
- 6) Approach Airspeed - 70-75 MPH.
- 7) Throttle - as necessary for desired glide path.
- 8) After Touchdown - Power Off, brake as required.
- 9) Electric Fuel Pump - OFF.

Aircraft landing characteristics are conventional for a tail-wheel airplane. Either wheel landings or full stalls (3 point) are permissible. During gusty wind conditions, increase airspeed approximately 5 mph above normal.

As a general rule, it is good practice to contact the ground at a minimum safe speed consistent with existing conditions. In calm or light wind conditions and in short and/or soft field conditions, a full stall landing is recommended. In a full stall landing, the flare or round-out should be made with power off. A three-point landing attitude should be held just above the ground while increasing the back pressure on the stick as airspeed drops until the stick is in the full aft position at the time of touchdown. Brake as necessary.

In high gusty wind or when a crosswind exists, a wheel landing is recommended, preceded by an approach of about 75 to 80 mph. The flare is made with slight power (900-1200 RPM) to a level flight attitude just above the ground. Contact with the ground is made on the main landing gear. At the time of contact, the stick is brought slightly forward of neutral to hold the airplane firmly on the ground in a tail up attitude. As speed decreases, lower the tail slowly to the ground and then hold full aft stick. Brake as necessary. During crosswind conditions, maintain cross-control corrections by using the rudder to maintain runway heading and the ailerons to correct for wind drift throughout the landing flare and roll-out.

### CAUTION

The use of wheel brakes is not recommended until after the tail wheel is in contact with the ground. For maximum braking, the control stick should be FULL AFT.

## LANDING - OBSTACLE/SHORT FIELD

Use Normal Landing procedures with following additions:

- 1) Approach Airspeed - 55 MPH Decathlon Standard and CS,  
60 MPH Super Decathlon .
- 2) Throttle - AS DESIRED to control rate of descent .

### WARNING

A relatively high rate of descent is possible in this configuration when at full gross weight and the throttle closed. If airspeed is allowed to decrease below the approach speeds shown, landing flare can only be assured with an application of power.

- 3) Slip aircraft as necessary to increase rate of descent.
- 4) Touchdown in full stall three-point attitude with stick full back.
- 5) Brake as required.

### WARNING

As speed decreases, braking must be moderated to prevent possible nose-over.

## LANDING - SOFT FIELD

Use Normal Landing procedure with following additions:

- 1) Approach - Use Normal or Obstacle Landing procedure.
- 2) Flare to three-point landing attitude and add small amount of power.
- 3) Touchdown in full stall three-point attitude with stick full back.
- 4) Use power to assist in maintaining tail-low attitude.

### WARNING

Good pilot judgement and experience are required to determine suitability of a soft field for safe landing operation.

## SHUTDOWN

- 1) Brakes - SET.
- 2) Electrical Equipment - OFF.
- 3) Mixture - IDLE CUT-OFF.
- 4) Magnetos/Master Switch - OFF after propeller stops.
- 5) Controls - SECURE with lap belt around forward control stick only.
- 6) Wheels - CHOCKED.
- 7) Wing/Tail Tie Downs - SECURE.

Before engine shutdown, turn off all radio equipment and other electrical equipment. The engine is shut down by closing the throttle and pulling the mixture control full aft to the idle cut-off. After the engine stops, turn off the master switch and both magnetos.

### NOTE

If high winds are anticipated, the aircraft should be hangared. If the aircraft must be left out, park into the wind and use additional tie-down ropes for security. Secure the forward control stick with the lap belt.

## GROUND HANDLING

The Decathlon is easily handled on the ground by using the handle on the lower right side of the fuselage just forward of the tail section. The tail can be lifted and the airplane can be pushed, pulled and turned from this position. Tie-down rings are provided under each wing on the main wing strut. The tail is secured by tying the rope or chain through the tail wheel unit. The aileron and elevators can be locked by securing the seat belt around the front control stick in a full aft position. Ground handlers should specifically avoid pushing or pulling on propeller spinner, propeller tips, wing struts, fuselage stringers or tail surfaces.

### WARNING

DO NOT push or pull on wing struts to move aircraft. Struts can be damaged by improper handling.

# SECTION IV

## FLIGHT PERFORMANCE

### INDEX

GENERAL.....	4-1
AIRSPEED CALIBRATION.....	4-2
STALL SPEEDS.....	4-3
TAKEOFF DISTANCE	
DECATHLON (STANDARD).....	4-4
DECATHLON CS.....	4-5
SUPER DECATHLON.....	4-6
TIME, FUEL AND DISTANCE TO CLIMB	
DECATHLON (STANDARD).....	4-7
DECATHLON CS.....	4-8
SUPER DECATHLON.....	4-9
CRUISE PERFORMANCE	
DECATHLON (STANDARD).....	4-10
DECATHLON CS.....	4-11
SUPER DECATHLON.....	4-12
LANDING DISTANCE.....	4-13

### GENERAL

This data is to inform the pilot what he can expect from the aircraft in the way of performance and to assist in preflight planning.

Flight performance data is included for all Decathlon models. The data has been compiled from both estimated calculations and actual flight test using average piloting techniques, with an aircraft and engine in good operating conditions. All information is corrected for standard atmospheric conditions.

Performance may vary from the given data due to the many possible variables present with a specific aircraft and flight condition. The pilot is therefore encouraged to maintain a personal flight log for his aircraft. This will not only provide more accurate preflight planning information for future flights, but also can be used as an indicator in determining the general condition of a particular aircraft.

### WARNING

Flight performance between the different Decathlon models varies significantly. This manual includes the performance data for all models. It is the pilot's responsibility to insure that the correct performance chart is used for a specific Decathlon model.

## AIRSPEED CALIBRATION

DECATHLON (STANDARD)  
DECATHLON CS

CAS (mph)	IAS (mph)
56	50
60	55
70	66
80	77
90	88
100	98
120	120
140	142
160	163
180	184

SUPER DECATHLON

CAS (mph)	IAS (mph)
60	60
70	70
80	80
90	90
100	100
120	120
140	141
160	163
180	184
200	206

NOTES

1. Assumes zero instrument error.
2. Maximum gross weight of 1800 lbs. at the forward C.G. limit.

## STALL SPEEDS

Model	CAS (mph)			
	Angle of Bank			
	0°	20°	30°	40°
Decathlon (Standard) Decathlon CS	53	55	61	75
Super Decathlon	53	55	61	75

### NOTES

1. Gross weight of 1800 lbs.
2. Power off.

## TAKEOFF DISTANCE

## SUPER DECATHLON

CONDITIONS

1. Level, Hard Surface, Dry Runway.
2. Zero Wind.
3. Aircraft Loaded to 1800 Lbs.

PILOT TECHNIQUE: Refer to "TAKEOFF-OBSTACLE" in Section III.

1. Speed at Lift-Off - 50 mph IAS.
2. Speed at 50 Feet - 58 mph IAS.

## WARNING

The aircraft must be pitched forward to a safe power-off speed should a power failure occur during climb-out; failure to respond immediately may result in a stall at low altitude.

Pressure Altitude Ft.	Distance (Ft.)									
	0° C		10° C		20° C		30° C		40° C	
	Ground Run	Total To Clear 50'	Ground Run	Total To Clear 50'	Ground Run	Total To Clear 50'	Ground Run	Total To Clear 50'	Ground Run	Total To Clear 50'
0	456	833	481	879	508	928	533	975	559	1021
1000	485	886	512	935	540	987	567	1036	594	1087
2000	520	951	550	1005	578	1057	608	1112	639	1169
3000	561	1026	591	1081	624	1141	657	1201	688	1258
4000	602	1101	635	1161	670	1224	704	1287	740	1354
5000	652	1192	690	1261	725	1326	762	1394	802	1466
6000	708	1294	746	1363	781	1438	828	1514	869	1588

NOTES

1. Data presented in this table represents maximum airplane capability at speeds shown and requires aircraft in good operating condition and a proficient pilot.
2. Decrease distance 20% for each 10 mph of head wind.
3. This data does not consider the effects of takeoff from soft **and/or grass** fields and takeoff with tail wind. Takeoff performance under these conditions vary substantially. Good pilot judgement **must** be used **under all conditions** to insure safe operation.



## TIME, FUEL AND DISTANCE TO CLIMB

### SUPER DECATHLON

#### CONDITIONS

1. Standard Temperature.
2. Aircraft Loaded to Gross Weight of 1800 Lbs.
3. Full Throttle, 2700 RPM.

PILOT TECHNIQUE: Refer to "CLIMB" in Section III.

1. Maximum Rate of Climb.
2. Lean Only as Required to Maintain Smooth Engine Operation.

Pressure Altitude (ft)	Standard Temp (°C)	Climb Speed (mph-IAS)	Rate of Climb (fpm)	From Sea Level		
				Time (min)	Fuel (gal)	Distance (sm)
0	15	80	1230	0	1.0	0
1000	13	80	1160	1	1.2	1
2000	11	79	1090	2	1.4	2
3000	9	79	1020	3	1.7	4
4000	7	78	940	4	1.9	5
5000	5	78	880	5	2.2	7
6000	3	77	790	6	2.4	8
7000	1	77	730	7	2.7	10
8000	-1	76	660	9	3.0	12
9000	-3	75	590	10	3.3	14
10000	-5	75	520	12	3.7	17
11000	-7	74	440	14	4.0	20
12000	-9	74	370	17	4.5	24
13000	-11	73	300	20	5.0	28
14000	-13	73	230	23	5.6	34
15000	-15	72	160	29	6.4	42

#### NOTES

1. Data presented in this table represents maximum airplane capability at speeds shown and requires aircraft in good operating condition and a proficient pilot.
2. Distances shown are based on zero wind.
3. Allow one gallon fuel for engine start, taxi and takeoff.
4. Decrease distance for head wind or increase distance for tail wind with the following increment:  $\text{Time (min)} / 60 \times \text{wind component in the direction of flight (mph)}$ .

## CRUISE PERFORMANCE

## SUPER DECATHLON

## CONDITIONS

1. Standard temperature.
2. All figures based on gross weight of 1800 lbs.
3. Maximum cruise is normally limited to 75% power.
4. All fuel consumption estimates are based on the recommended lean mixture (see Section III) when at or below 75% power and full rich above 75% power.

% POWER	RPM	M.P.	TAS MPH	GPH
---------	-----	------	---------	-----

## 2500 Ft.

85	2600	25.3	151	12.5
80		24.1	147	12.0
75		23.0	144	9.7
70		21.8	139	9.3
65		20.6	136	8.8
60		19.5	131	8.3

85	2500	25.9	151	12.3
80		24.7	147	11.8
75		23.5	144	9.6
70		22.3	139	9.1
65		21.1	136	8.7
60		19.9	131	8.1

85	2400	26.5	151	12.2
80		25.2	147	11.5
75		24.0	144	9.5
70		22.8	139	8.9
65		21.5	136	8.5
60		20.3	131	8.0

## 5000 Ft.

80	2600	23.6	151	12.0
75		22.4	147	9.7
70		21.3	143	9.3
65		20.1	139	8.8
60		18.9	134	8.3
55		17.7	128	7.9

80	2500	24.1	151	11.8
75		22.9	147	9.6
70		21.7	143	9.1
65		20.5	139	8.7
60		19.3	134	8.1
55		18.1	128	7.7

80	2400	24.9	151	11.5
75		23.6	147	9.5
70		22.3	143	8.9
65		21.0	139	8.5
60		19.8	134	8.0
55		18.5	128	7.6

% POWER	RPM	M.P.	TAS MPH	GPH
---------	-----	------	---------	-----

## 7500 Ft.

80	2600	23.0	154	12.0
75		21.8	151	9.7
70		20.6	146	9.3
65		19.5	141	8.8
60		18.4	136	8.3
55		17.2	131	7.9

80	2500	23.6	154	11.8
75		22.4	151	9.6
70		21.2	146	9.1
65		20.0	141	8.7
60		18.7	136	8.1
55		17.5	131	7.7

80	2400	24.3	154	11.5
75		23.0	151	9.5
70		21.8	146	8.9
65		20.5	141	8.5
60		19.2	136	8.0
55		18.0	131	7.6

## 10,000 Ft.

70	2600	20.2	150	9.3
65		19.0	145	8.8
60		17.8	139	8.3
55		16.7	133	7.9
50		15.5	125	7.4

70	2500	20.6	150	9.1
65		19.4	145	8.7
60		18.2	139	8.1
55		17.0	133	7.7
50		15.8	125	7.2

70	2400	21.2	150	8.9
65		20.0	145	8.5
60		18.7	139	8.0
55		17.4	133	7.6
50		16.2	125	7.1

## NOTE

Speeds shown based on aircraft with optional strut fairings and streamlined tail wires. Reduce figures shown by 2% for aircraft not so equipped.

## LANDING DISTANCE

### CONDITIONS

1. Level, Hard surface, dry runway.
2. Zero wind.
3. Aircraft loaded to 1800 lbs.

PILOT TECHNIQUE: (Refer to "LANDING-OBSTACLE/SHORT FIELD" in Section III.)

1. Approach Speed - 55 mph-IAS Decathlon Standard and CS  
- 60 mph-IAS Super Decathlon
2. Throttle - as required to control descent rate.
3. Maximum braking.

### WARNING

A relatively high rate of descent is possible in this configuration when at full gross weight and the throttle closed. If airspeed is allowed to decrease below the approach speeds shown, landing flare can only be assured with an application of power.

Pressure Altitude Ft.	Distance (°F)									
	0° C		10° C		20° C		30° C		40° C	
	Ground Roll	Total To Clear 50'	Ground Roll	Total To Clear 50'	Ground Roll	Total To Clear 50'	Ground Roll	Total To Clear 50'	Ground Roll	Total To Clear 50'
0	413	1023	421	1042	428	1060	435	1078	442	1095
1000	421	1042	428	1060	436	1080	443	1097	450	1114
2000	429	1062	437	1081	444	1099	452	1118	459	1137
3000	437	1081	445	1100	453	1120	460	1140	468	1157
4000	445	1102	453	1120	461	1141	469	1160	476	1179
5000	453	1122	462	1143	470	1162	478	1182	486	1202
6000	462	1143	470	1164	479	1185	487	1205	495	1225

### NOTES

1. Data presented in this table represents maximum airplane capability at speeds shown and requires aircraft in good operating condition and a proficient pilot.
2. Decrease the distance shown by 20% for each 10 mph of head wind.

## SECTION V

# WEIGHT AND BALANCE

### INDEX

GENERAL.....	5-1
LOADING PROCEDURES.....	5-2
SAMPLE LOADING PROBLEM.....	5-3
LOADING GRAPH.....	5-4
FLIGHT ENVELOPE(S).....	5-5

### GENERAL

It is the pilot's responsibility to insure that the aircraft is loaded properly and within the weight and balance limitations. All flight performance, procedures and characteristics are based on this prerequisite.

If the aircraft is to be used for aerobatic flight, it must be loaded within the approved flight envelope. The rear center-of-gravity limit is considered critical. In addition, no baggage is allowed.

The gross weight limit is the same for both normal and acrobatic category. The importance of this limit cannot be over emphasized especially when performing aerobatics. Subjecting the aircraft to the maximum approved load factor limits in an overgross condition may result in damage or complete structural failure of the airframe.

The actual licensed empty weight and center of gravity (C.G.) of a specific aircraft can be found in Section 4 of the FAA Approved Airplane Flight Manual. All additional changes to the aircraft empty weight and C.G. after the time of manufacture must also be attached to Section 4 of the flight manual. From this information and the following instructions, the pilot can easily determine the "Useful Load" and proper loading distribution for the aircraft.

A loading graph and flight envelope is given in this section and in Section 4 of the FAA Approved Flight Manual as an aid to weight and balance calculation.

### NOTE

The rear center of gravity limits vary from the Decathlon to the Super Decathlon. A flight envelope is provided for each model.

## LOADING PROCEDURE

1. Determine from the Weight and Balance Sheet, in the aircraft file, the "Licensed Empty Weight and Moment" (in-lbs). Enter these figures under "Your Airplane" of the Sample Loading Problem, Figure 5-1.
2. Full oil capacity can be assumed for all flights. For ease of future loading computations, the new "Empty Weight and Moment With Oil" should be determined and entered in the Sample Loading Problem under "Your Airplane".
3. Using the Loading Graph, Figure 5-2, determine the weight and the moment of the following items and enter these figures on the Sample Loading Problem.
  - a) Pilot
  - b) Rear Passenger
  - c) Wing Fuel - 40 Gals. Maximum Useable @ 6 Lbs./Gal.
  - d) Baggage - 100 Lbs. Maximum (Normal Category Only)
4. Add the "Aircraft Empty Weight and Moment with Oil" and all the items in Step 3 to determine the "Gross Takeoff Weight and Moment".
5. Using the Flight Envelope, Figures 5-3 or 5-4, for the model Decathlon used, determine that the gross takeoff weight and moment are within limits.

### WARNING

If the aircraft is not within the approved flight envelope limits, it must be reloaded. Under no circumstances should the aircraft be flown with an out of limits condition, particularly if aerobatic flight is contemplated.

SAMPLE LOADING PROBLEM				
ITEM	SAMPLE AIRPLANE		YOUR AIRPLANE	
	WEIGHT (lbs)	MOMENT (in-lbs)	WEIGHT (lbs)	MOMENT (in-lbs)
1) Licensed Empty Weight	1270	17851	1339.01	16208
Oil-8 qts @ 7.5 lbs/gals	+15	-543	+15	-543
2) Licensed Empty Weight & Moment With Oil	1285	17308	1353.01	15665
3) Pilot	190	3025		
Rear Passenger	190	8500		
Wing Fuel 40 Gals Max @ 6 lbs/gal	120 (20 gal)	3125		
Baggage-100 lbs Max (Normal Category Only)	-0-	-0-		
4) Gross Takeoff Weight & Moment	1785	31958		

- NOTE: 1) Use Figure 5-2 loading graph to determine moment.
- 2) To determine Takeoff Center of Gravity (inches aft of datum), divide the Gross Takeoff Moment by the Gross Takeoff Weight. Center of Gravity Limits are listed in Section I.
- 3) The above sample problem is loaded for aerobatic flight conditions and assumes a 170 pound pilot and passenger with parachutes.

FIGURE 5-1 SAMPLE LOADING PROBLEM

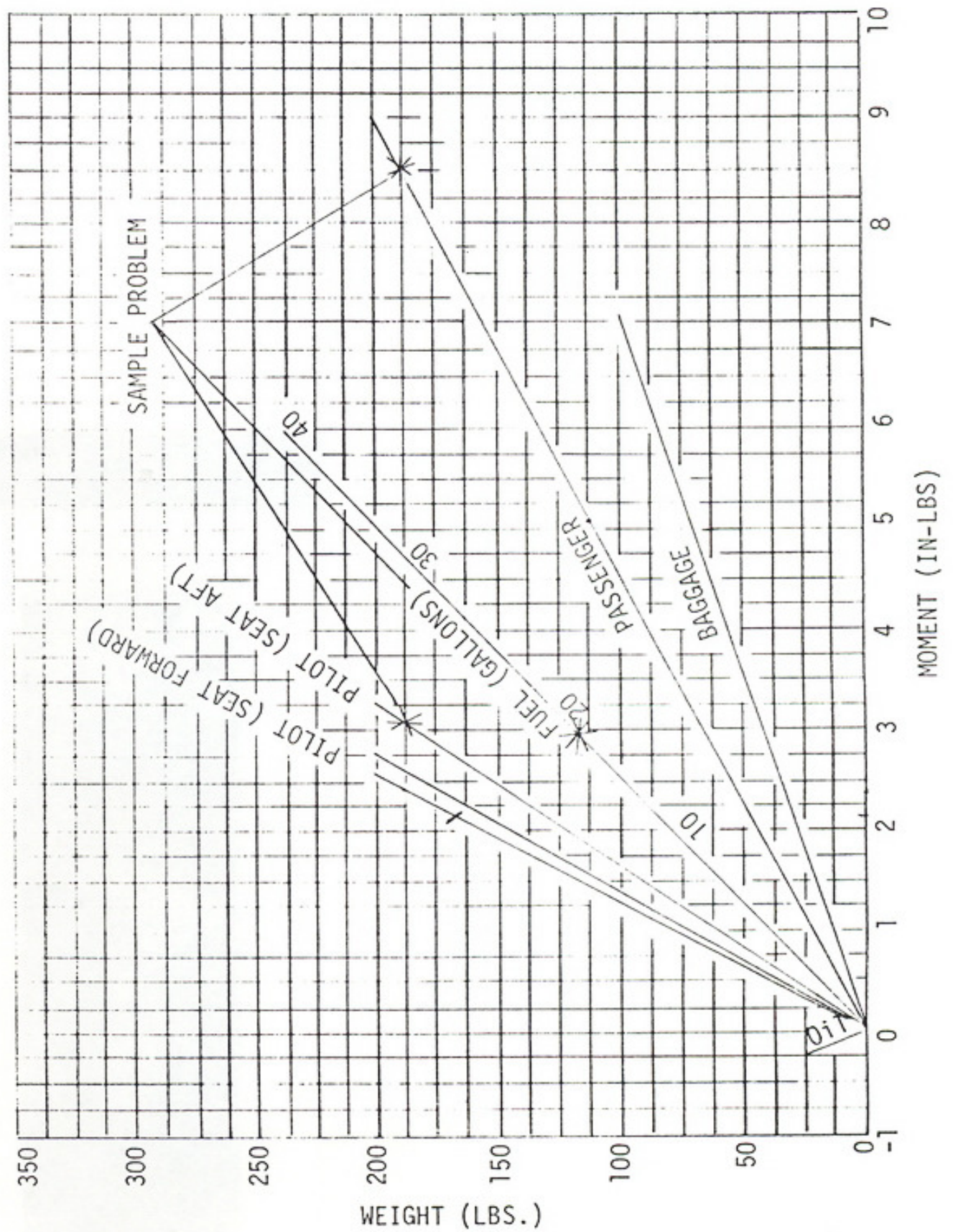

FIGURE 5-2 LOADING GRAPH (All Decathlon Models)

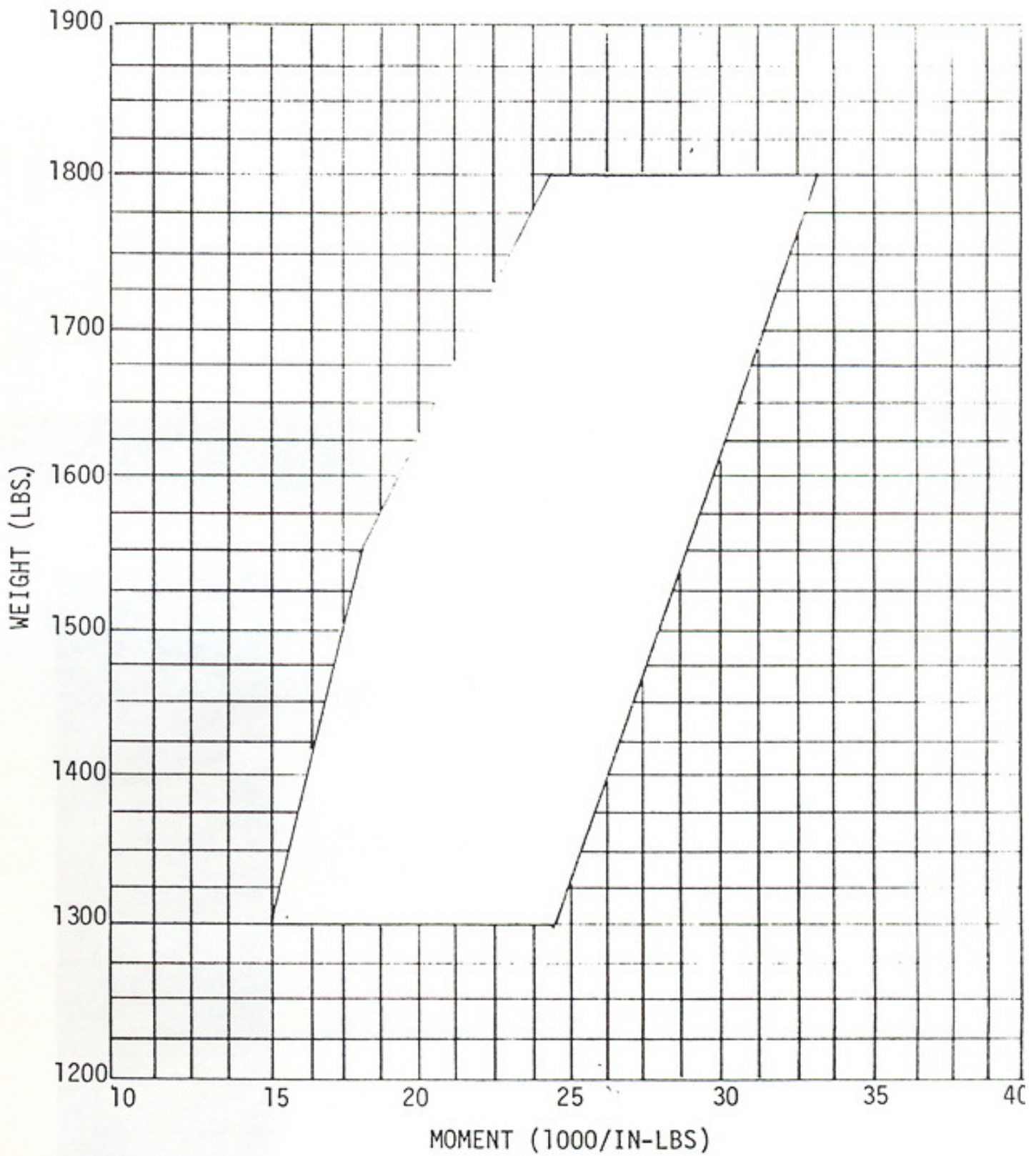

FIGURE 5-4 SUPER DECATHLON WEIGHT AND  
BALANCE FLIGHT ENVELOPE



# SECTION VI

## AIRCRAFT AND SYSTEM DESCRIPTION

### INDEX

GENERAL.....	6-2
ENGINE/PROPELLER.....	6-2
THROTTLE CONTROL.....	6-2
ALTERNATE AIR CONTROL.....	6-2
MIXTURE CONTROL.....	6-2
ELECTRIC FUEL PUMP CONTROL.....	6-2
BATTERY.....	6-3
ALTERNATOR.....	6-3
OVER VOLTAGE CONTROL.....	6-3
VOLTAGE REGULATOR.....	6-3
ELECTRICAL PANEL.....	6-3
MASTER SWITCH.....	6-3
IGNITION SWITCHES.....	6-4
EQUIPMENT SWITCHES.....	6-4
FUSES.....	6-4
STARTER SWITCH.....	6-4
AMMETER.....	6-4
SEATS.....	6-4
BRAKES.....	6-5
CABIN DOOR.....	6-5
INSTRUMENTS.....	6-5
SEAT BELTS AND HARNESSSES.....	6-6
PITOT-STATIC SYSTEM.....	6-6
ELEVATOR TRIM TAB.....	6-6
CABIN HEATER.....	6-6
BAGGAGE COMPARTMENT.....	6-6
ENGINE OIL SYSTEM.....	6-7
INDUCTION AIR FILTER.....	6-7
TIRES.....	6-7
FUEL SYSTEM.....	6-7
VENT SYSTEM.....	6-10
SYSTEM OPERATION.....	6-10
FUEL PUMPS.....	6-10
PRIMER.....	6-10
FUEL PRESSURE GAUGE.....	6-10
HEADER TANK.....	6-11

## GENERAL

The Decathlon is a single engine tandem two place, strut braced high wing airplane. The fuselage is a welded steel tube frame and the wing is constructed from formed aluminum ribs and Sitka spruce spars. The airframe is covered with Dacron and finished with Nitrate and Butyrate dopes.

## ENGINE / PROPELLER

The engine is a Lycoming normally aspirated, direct drive, air cooled, horizontally opposed, four-cylinder engine. The engine oil system differs from a conventional wet sump type in that its design provides for both normal and inverted operations. See Figure 6-1 for the system schematic and detailed operational information.

The Hartzell propeller on the Decathlon C/S and Super Decathlon is a counterweighted constant speed propeller. The counterweights provide a fail safe feature causing the propeller to go to low RPM if oil pressure is lost. This protects against a possible overspeed condition. A venier propeller control is located at the left side of the instrument panel.

The Decathlon (Standard) uses a fixed pitch 74 inch diameter propeller.

## THROTTLE CONTROL

The throttle control is in a quadrant on the left side of the cabin with front and rear throttles interconnected.

## ALTERNATE AIR CONTROL

This control is located directly below the throttle. Alternate hot air is provided by pulling the control knob to the rear. Extended use of alternate air is not recommended as this air is not filtered.

## MIXTURE CONTROL

This control is located on the left side of the instrument panel. To lean the mixture (at 75% power or below), pull the control away from the panel as required. Pulling the mixture control all the way out, provides the fuel cutoff to the engine.

## ELECTRIC FUEL PUMP CONTROL

The switch for the electric fuel pump is located on the control panel next to the mixture control.

## BATTERY

The Decathlon has a conventional lead-acid storage battery. The battery is located behind the baggage compartment and is equipped with special non-spill caps and vent system. The battery and vent manifold is enclosed in a leak proof case with a transparent removeable cover.

The battery must be inspected frequently when the aircraft is being used for aerobatics and serviced in accordance with instructions in Section VII of this manual.

## ALTERNATOR

The 60 amp alternator provides charging current and has sufficient capacity to operate all electrical equipment without battery drain. During inverted flight, the charging circuit is disconnected by a mercury switch.

## OVER VOLTAGE CONTROL

The airplane electrical system is protected from surge by an over voltage control which is mounted on the top right side of the firewall. The over voltage control can be reset by cycling the master switch on-off-on.

## VOLTAGE REGULATOR

Alternator output is controlled by the voltage regulator. This regulator also protects the alternator circuit against overload and should be adjusted only by a qualified mechanic.

## ELECTRICAL PANEL

All electrical switches (except the starter and the electric fuel pump switch), fuses, and fuse spares are on the electrical panel located on the upper left side of the cabin.

## MASTER SWITCH

The master switch is on the electrical panel and activates the master switch solenoid which connects the battery and alternator to the rest of the electrical system. Electrical equipment will not operate with the master switch off; however, the engine will run with the master switch off since ignition is provided by the magnetos.

## IGNITION SWITCHES

Ignition switches for the left and right magnetos are to the right of the master switch. Since ignition is provided by the magnetos, the ignition switches must be on to operate the engine.

## EQUIPMENT SWITCHES

Switches for operation of standard electrical equipment--navigational lights, landing light and optional equipment are to the left of the master switch.

## FUSES

Each electrical accessory is protected by a separate fuse directly above the electrical switch. Spare fuses are also provided on the electrical panel. To check fuse, push in and twist fuse cap counterclockwise to release cap from electrical panel. If the wire strand inside the fuse is loose or broken, either the fuse is defective or the circuit load has exceeded the fuse rating. To avoid circuit damage, always use a correctly-rated fuse for replacement.

## STARTER SWITCH

A push button switch, located on the control panel, operates the electrical starter. The master switch must be on to operate the starter.

## AMMETER

The ammeter measures current to or from the battery. A normal condition is indicated by a zero reading or a plus reading on the ammeter. A negative reading indicates a current draw from the battery which can result from an overloaded system or a faulty charging system.

## SEATS

Front and rear seats are welded steel tube construction with removeable cushions to permit the use of parachutes. The front seat is adjustable fore and aft. The adjustment control knob is located on the right underside of the seat. Adjustments should be made before taxi or takeoff as necessary to insure full and comfortable access to all required controls.

## BRAKES

Hydraulic brakes are provided for both front and rear seats. A parking brake control is also provided. To operate the parking brake, depress the brake pedals and pull out the control located under the far right side of the instrument panel. To release the parking brake, push the control all the way in.

## CABIN DOOR

The Decathlon is equipped with a cabin door which can be jettisoned if necessary. The door is secured by a lock-equipped latch at the rear edge and a latch on the top and forward edge.

The emergency door release handle is near the forward edge of the door.

To jettison the cabin door:

1. To operate the door jettison handle, pull the red ring firmly to remove the safety locking pin, then pull the red handle aft and up as far as possible. This removes the door hinge pins.
2. Push or kick the door free of the aircraft.

### NOTE

If necessary, emergency exit may be made from the left side of the aircraft by opening the left side window and forcing it past its hinge strap by pushing hard on forward window frame.

## INSTRUMENTS

All instruments except the fuel gauge are on the instrument panel directly in front of the pilot. Basic instruments are marked with a green arc for the normal operating range, a yellow arc for the caution range and red radial lines for maximum or minimum permissible values. Specific markings for each instrument are given in the FAA Approved Airplane Flight Manual.

## SEAT BELTS AND HARNESSSES

All Decathlons are equipped with lap belts and shoulder harnesses in both front and rear seats. A secondary inverted harness is available as optional equipment (standard in Decathlon CS and Super Decathlon front seat).

The secondary inverted flight harness consists of a double strap shoulder harness, a lap belt and a crotch strap. A five point rotary buckle connects the strap and will release the shoulder harness and lap belt with one movement.

The primary harness may be used alone; however, the inverted harness should not be used without the primary shoulder harness. The inverted harness does not restrain the pilot from forward movement.

## PITOT STATIC SYSTEM

The pitot tube is located on the bottom side of the left wing. The static ports are located on the side of the aircraft just aft of the cabin section (one port on each side of the aircraft).

## ELEVATOR TRIM TAB

The trim tab control is mounted on the left side of the cabin. This type of trim control permits very rapid trim inputs if necessary. Rudder trim is provided by a ground adjustable tab.

## CABIN HEATER

Cabin heat is provided by an exhaust shroud heater. An optional rear seat heater provides additional heat to the rear of the cabin whenever alternate air is not in use.

Push-pull heater control is located on the left side of the cabin under the instrument panel. The optional rear heater control is located on the right side of the cabin under the instrument panel.

## BAGGAGE COMPARTMENT

The baggage compartment behind the rear seat accommodates 100 lbs. of baggage or cargo. The back of the seat folds for access.

No baggage or loose articles are to be carried during aerobatic flight.

## ENGINE OIL SYSTEM

Figure 6-1 presents the oil system schematic and detailed operational information. Components related to propeller control system are not shown.

### NOTE

Oil pressure during inverted flight may normally be five to ten pounds less than oil pressure during normal flight.

Figure 6-1 shows the basic operating principles involved in the oil system. For more detailed information concerning a particular engine model, see the Lycoming Engine Operator's Manual.

## INDUCTION AIR FILTER

An induction air filter is located in the cowling and filters all air entering the engine. Alternate (hot) air is not filtered and continuous use is not recommended.

## TIRES

The Decathlon is fitted with conventional aircraft type 6.00 x 6, 4 or 6 ply tires.

## FUEL SYSTEM

The fuel system is shown in Figure 6-2. Welded aluminum fuel tanks are located in the inboard section of the wing. Two 20 gallon tanks are standard. Wing tanks proper can be drained by removing a  $\frac{1}{4}$ " pipe plug from the inboard corner of the tank. Fuel lines between the tanks and the rear sump are drained from a quick drain on the belly of the aircraft.

The gascolator is mounted on the firewall in the engine compartment. The gascolator is drained by a remote actuated quick drain control which can be reached through the oil dipstick access door in the cowl. The sediment bowl is removeable for cleaning and replacement of the fuel filter. The fuel shut-off valve is located on the left side of the cabin. The Decathlon fuel system is an "ON - OFF" system.

Fuel quantity is read from mechanical float type gauge(s) located in the fuel tank(s). These gauges are only accurate in the level flight attitude.

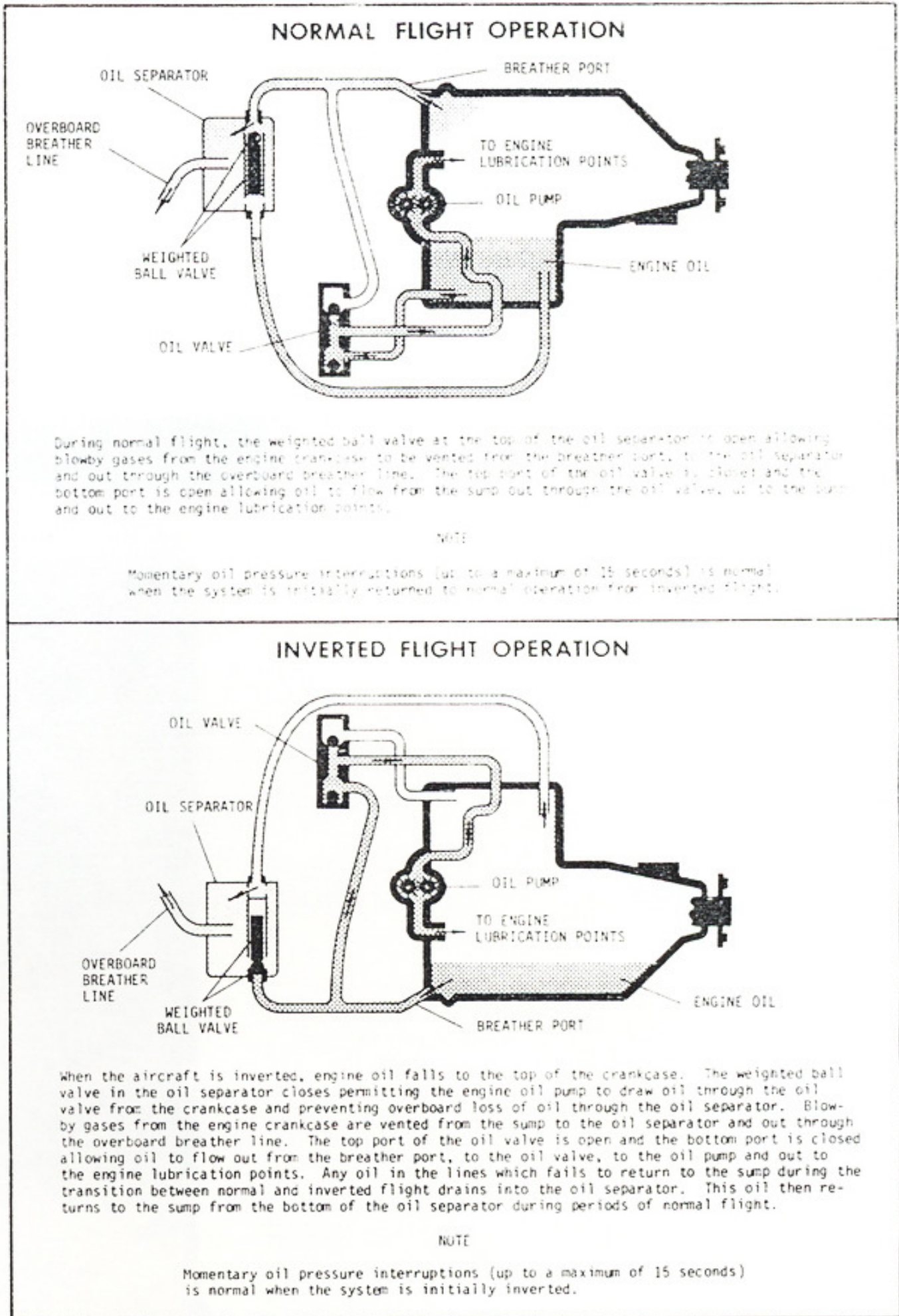

FIGURE 6-1 OIL SYSTEM SCHEMATIC



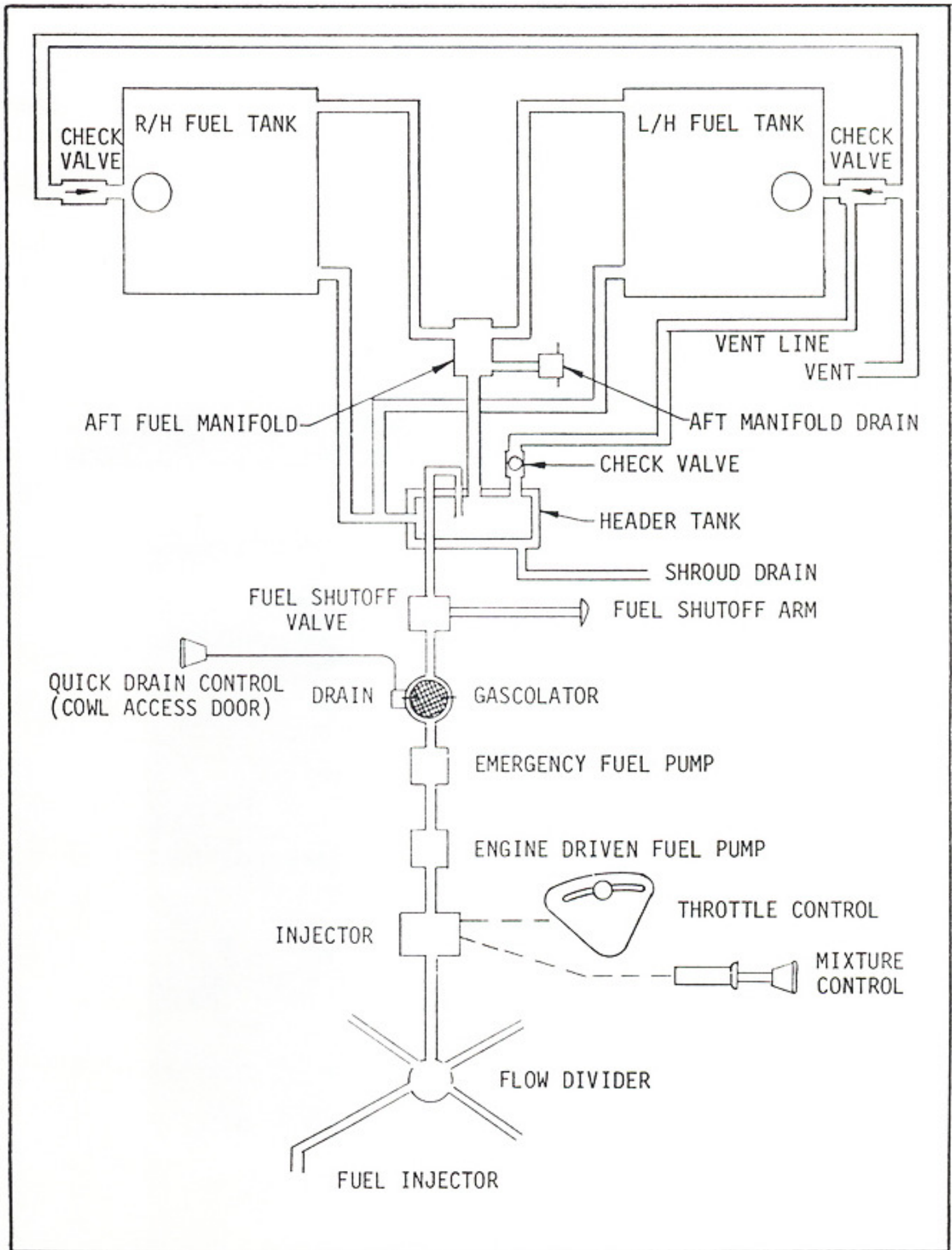

FIGURE 6-2 FUEL SYSTEM SCHEMATIC

## **VENT SYSTEM**

Fuel tank air spaces are interconnected and positive venting is provided through a tube which protrudes from the bottom of the left wing just outboard of the tank. A check valve is provided at the vent outlet of each tank to minimize inverted fuel loss.

## **SYSTEM OPERATION**

Fuel is gravity fed from the tanks to the engine.

## **FUEL PUMPS**

The Decathlon engine is fuel injected and two fuel pumps are required.

1. An engine-driven, cam-operated pump which operates whenever the engine is running to supply fuel at proper pressure to the fuel injector.
2. An emergency electric pump on the firewall in the engine compartment. The control switch for the electric fuel pump is located on the control panel next to the mixture control.

## **PRIMER**

To prime the engine, turn on the master switch and the electric fuel pump with throttle closed and mixture in idle cut-off. To provide one stroke of prime, move mixture control to full rich and back to idle cut-off. This injects fuel directly into the cylinders. Return electric fuel pump to "OFF" after priming.

## **FUEL PRESSURE GAUGE**

The fuel pressure gauge on the right side of the instrument panel indicates the fuel pressure at the injector inlet.

## HEADER TANK

To provide limited fuel in the inverted position, a shrouded 1.5 gallon header tanks is located in the forward cabin under the instrument panel. The outlet from the header tank consists of a standpipe located at the center of the tank. Thus half of the tank capacity can be used in the inverted position. Even though the inverted fuel supply has not been exhausted, inverted flight must be terminated immediately if oil pressure should drop below acceptable limits.

### NOTE

The fuel filler cap used on the Decathlon is a non-venting type. A loose cap, or one that is not sealing properly, may cause a fuel unbalance from one tank to another. If an excessive fuel unbalance exists, check the caps for security and the filler cap gasket for condition. Flying the aircraft in an uncoordinated manner or parking the aircraft on a slope may also cause fuel unbalance. Do not assume fuel in left tank is identical to that shown on right tank fuel gauge.

## SECTION VII

# SERVICING REQUIREMENTS

### INDEX

GENERAL.....	7-1
EXTERIOR CARE.....	7-1
WINDSHIELD AND WINDOW CARE.....	7-2
BATTERY BOX.....	7-3
FUEL AND OIL.....	7-3
REQUIREMENTS FOR NEW ENGINES.....	7-4
CHANGING ENGINE OIL.....	7-4
ENGINE COWLING.....	7-6
BRAKE SERVICING.....	7-6

### GENERAL

Certain maintenance and general attention items will assure a long life and maximum reliability for any aircraft. General procedures and care hints for the Decathlon are covered in this section.

For complete servicing instructions, refer to the Decathlon Service Manual.

### EXTERIOR CARE

Your Decathlon has a long-lasting, all weather finish and should require very little maintenance. However, it may be desirable to wax and polish the airplane. It is recommended that this work be delayed until at least 30 to 60 days after date of manufacture so that the paint may cure completely.

The finish can be kept bright simply by washing with water and mild soap. Avoid abrasive soaps or harsh detergents. Rinse with clear water and dry with terry cloth towels or chamois.

If you choose to wax your airplane, use a good aircraft type wax and apply wax liberally to areas subject to high abrasion such as leading edges of the wings and tail surfaces.

## WINDSHIELD AND WINDOW CARE

A certain amount of care is required to keep the plexiglass in the windshield and cabin windows clean and unscratched. The following cleaning procedure is recommended:

1. If large deposits of mud and dirt have accumulated on the plexiglass, flush with clean water and dislodge excess dirt and mud.
2. Wash with soap and water. Use a sponge or heavy wadding of soft cloth. Do not rub as the abrasive in the dirt and mud residue will cause fine scratches in the surface.
3. Grease and oil spots may be removed with a soft cloth soaked in kerosene.
4. After cleaning, wax the surface with a thin coat of hard polishing wax or a commercial brand of plexiglass polish. Buff with a soft cloth.
5. If a severe scratch or marring should occur, use jeweler's rouge to rub out the scratch. Smooth it and apply wax.

### NOTE

Never use gasoline, benzene, alcohol, acetone, carbon tetrachloride, anti-ice fluid, lacquer thinner or glass cleaner to clean the plexiglass. These materials will attack the plastic and may cause severe crazing.

## BATTERY BOX

The battery should be checked frequently for proper acid level, cleanliness of battery and security of cables and caps. The following special precautions must be followed to prevent leakage of acid.

1. Maintain acid level only 1/16" above top of the plates.
2. When servicing or installing battery, make a final acid level check after the airplane is flown long enough to completely charge the battery. Charging may cause acid level to rise, thus forcing acid into the battery caps. If battery is inverted with acid inside the caps, acid will run out.
3. Check frequently to insure that caps are tight.

### NOTE

If signs of acid spillage exists inside the case or battery box, neutralize all the spilled acid with soda and clean battery, battery box and other affected parts. Inspect the battery, battery caps and vent manifold and fix leak before next flight.

## FUEL AND OIL

Aviation grade 80/87 octane fuel is the standard fuel for the Decathlon and Decathlon CS. The Super Decathlon must use 100 octane minimum. Do not use any lower grade as it can cause serious engine damage in a very short time as well as engine failure.

Oil sump capacity is eight quarts and aerobatic minimum safe quantity is six quarts. Recommended time between change is 25 hours, or sooner, as conditions dictate. The following grades should be used for the specific temperatures.

AVERAGE TEMPERATURE	SINGLE VISCOSITY GRADES	MULTI-VISCOSITY GRADES
Above 60° F	SAE 50	SAE 40 or SAE 50
30° to 90° F	SAE 40	SAE 40
0° to 70° F	SAE 30	SAE 40 or 20W-30
Below 10° F	SAE 20	SAE 20W-30

All oils used must conform to Lycoming Spec. No. 301E.

## REQUIREMENTS FOR NEW ENGINES

Your engine is filled at the factory with the proper grade of straight mineral oil. Only straight mineral oil (not additive oil) should be used for the first 50 hours or until oil consumption stabilizes.

## CHANGING ENGINE OIL

It is recommended that engine oil be changed approximately every 25 hours. Depending on operating conditions, a longer or shorter period may be used at the discretion of the owner. To change the oil, first fly the airplane for a short period to allow oil to reach normal operation temperature. If your engine is not equipped with a Handi-Drain (optional), oil is drained by first removing the bottom engine cowling then unsafetying and removing the pipe plug on the right side of the oil sump bottom. After draining, reinstall plug, secure with safety wire and replace cowling.

### NOTE

Decathlon CS and Super Decathlon: Total capacity of oil sump, oil cooler and propeller control system equals ten quarts; however, only the eight quarts in the sump is represented on the dipstick calibration. Maintain your oil level in accordance with this calibration (eight quarts maximum, six quarts aerobatic minimum). Approximately eight of the ten total quarts is drainable.

It is recommended that the 25-hour oil change interval be observed for winter operations and that the oil and breather lines be checked for moisture accumulation during the oil change. It should be noted that draining the oil through the oil sump or quick-drain does not remove all of the oil from the system. For complete oil drainage, the oil should be drained through the sump plug and then the oil drained in lines A, B, C and D as shown in Figure 7-1. It is also recommended that an inspection be made for moisture accumulation at five to ten operating hour intervals at the locations shown in Figure 7-1. This inspection interval will be dependent upon the type of aircraft operation and the operational environment. All moisture and sludge should be drained from these locations during the inspections.

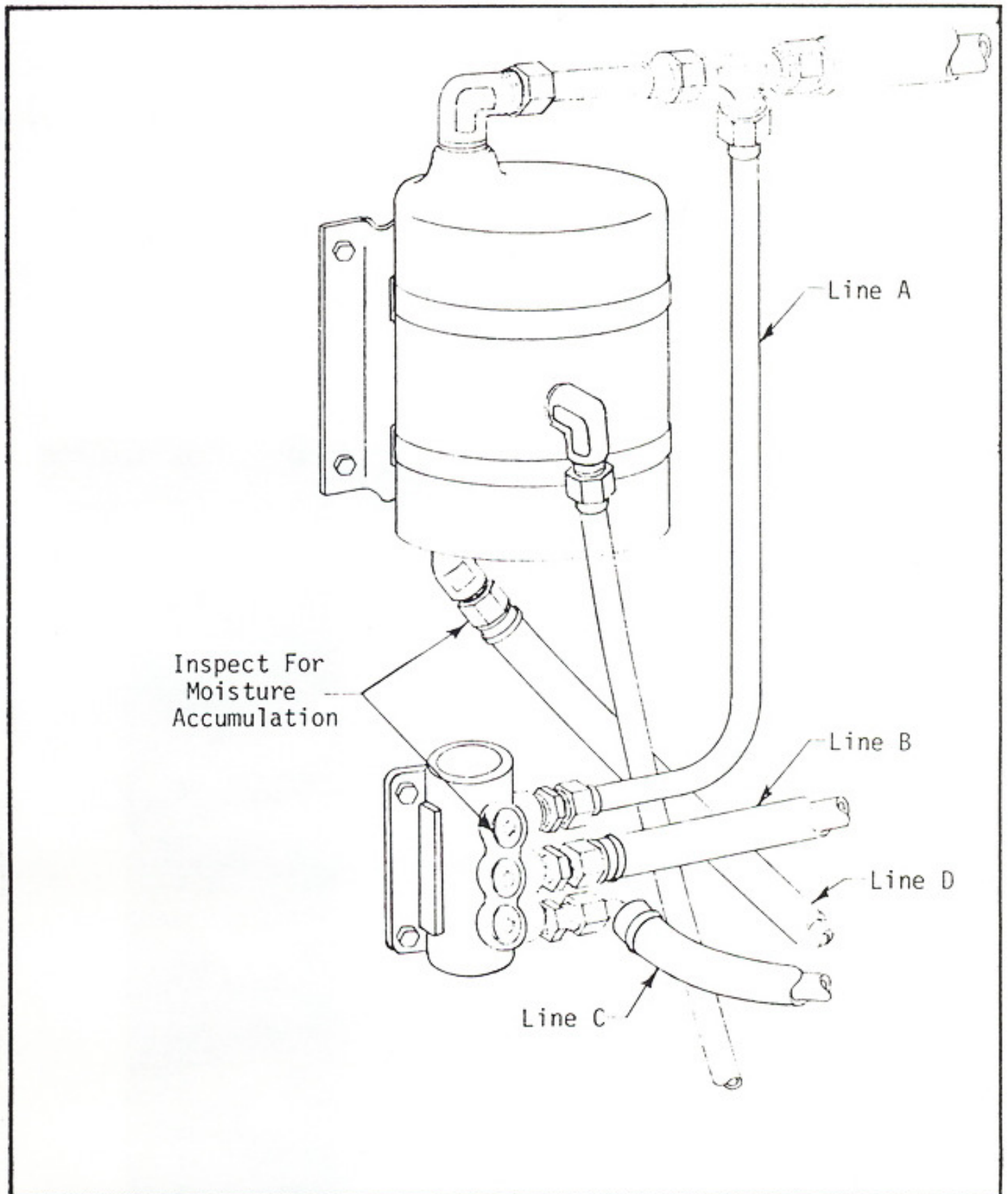

FIGURE 7-1 CHRISTEN OIL SYSTEM LINES  
AND INSPECTION POINTS



## ENGINE COWLING

The top half of the cowling can be quickly removed for inspection or maintenance by simply disconnecting the  $\frac{1}{2}$ -turn camlock fastener from the lower cowling and lifting the top cowl free. To remove the lower cowl once the top is removed:

1. Disconnect landing light wires at the right side of the cowl from the firewall.
2. Remove screws (10) from rear edge of cowl.
3. Pull cowl slightly forward and down.

Installation of cowl is in reverse order of removal. However, when installing lower cowl, insure that the rubber duct which connects the air filter to air in take manifold is installed over the connecting flange. When installing upper cowl, be certain rubberized cloth is in correct position to seal engine baffles to the cowl.

## BRAKE SERVICING

To fill and/or bleed the brake system, remove the rubber cap from the bleeder valve on the bottom of the brake assembly located on the gear leg at the axle attachment. Turn the valve open and connect a pressure brake bleeder to the valve. Fill brake until fluid runs out of the over flow tubes located on the underside of the fuselage cabin section. Continue to fill until the brake pedal pressure is firm. Close bleeder valve on the brake assembly before disconnecting the hose of the pressure pot. Each brake is filled separately. Use only MIL-H-5606 hydraulic fluid.